



中国认可  
国际互认  
检测  
TESTING  
CNAS L6478



# TEST REPORT

**Reference No.**..... : WTF20F05031546E  
**Applicant**..... : Mid Ocean Brands B.V.  
**Address**..... : 7/F., Kings Tower, 111 King Lam Street, Cheung Sha Wan, Kowloon,  
 Hong Kong  
**Manufacturer** ..... : 111587  
**Product Name**..... : Backpack in RPET w/COB light  
**Model No.**..... : MO9969  
**Standards**..... : EN 55015:2013+A1:2015  
 EN 61547:2009  
**Date of Receipt sample** .... : 2020-05-28  
**Date of Test** ..... : 2020-05-28 to 2020-05-29  
**Date of Issue**..... : 2020-05-29  
**Test Report Form No.**..... : WEL-55015A-01A  
**Test Result**..... : **Pass**

**Remarks:**

The results shown in this test report refer only to the sample(s) tested, this test report cannot be reproduced, except in full, without prior written permission of the company. The report would be invalid without specific stamp of test institute and the signatures of compiler and approver.

**Prepared By:**

**Waltek Services (Foshan) Co., Ltd.**

Address: No.13-19, 2/F., 2nd Building, Sunlink International Machinery City,  
 Chencun, Shunde District, Foshan, Guangdong, China

Tel:+86-757-23811398 Fax:+86-757-23811381 E-mail:info@waltek.com.cn

Compiled by:

*Leo Feng*

Leo Feng / Project Engineer

Approved by:



*Oran Yang*

Oran Yang / Manager



## 1 Test Summary

EMISSION				
Test Item	Test Standard	Class / Severity	Result	
Radiated Electromagnetic Disturbance, 9kHz to 30MHz	EN 55015:2013+A1:2015	Clause 4.4.1	Pass	
Radiated Emission, 30MHz to 300MHz	EN 55015:2013+A1:2015	Clause 4.4.2	Pass	
IMMUNITY (EN 61547: 2009)				
Test Item	Test Method	Class / Severity	Performance Criteria	Result
Electrostatic Discharge(ESD)	IEC 61000-4-2:2008	±4 kV Contact ±8 kV Air	B	Pass
Radio-Frequency Electromagnetic Fields (80MHz to 1GHz)	IEC 61000-4-3:2010	3V/m, 80%, 1kHz, Amp. Mod.	A	Pass

Remark:

Pass

Test item meets the requirement

Fail

Test item does not meet the requirement

N/A

Test case does not apply to the test object

# WALTEK



## 2 Contents

	Page
<b>COVER PAGE.....</b>	<b>1</b>
<b>1 TEST SUMMARY .....</b>	<b>2</b>
<b>2 CONTENTS .....</b>	<b>3</b>
<b>3 GENERAL INFORMATION.....</b>	<b>4</b>
3.1 GENERAL DESCRIPTION OF E.U.T. ....	4
3.2 DETAILS OF E.U.T. ....	4
3.3 DESCRIPTION OF SUPPORT UNITS .....	4
3.4 STANDARDS APPLICABLE FOR TESTING.....	4
3.5 TEST FACILITY.....	5
3.6 SUBCONTRACTED.....	5
3.7 ABNORMALITIES FROM STANDARD CONDITIONS.....	5
<b>4 EQUIPMENT USED DURING TEST.....</b>	<b>6</b>
4.1 SOFTWARE LIST .....	7
4.2 MEASUREMENT UNCERTAINTY .....	7
4.3 SPECIAL ACCESSORIES AND AUXILIARY EQUIPMENT .....	7
4.4 DECISION RULE.....	7
<b>5 EMISSION TEST RESULTS.....</b>	<b>8</b>
5.1 RADIATED ELECTROMAGNETIC DISTURBANCE, 9KHZ TO 30MHZ.....	8
5.1.1 <i>E.U.T. Operation</i> .....	8
5.1.2 <i>Block Diagram of Test Setup</i> .....	8
5.1.3 <i>Measurement Data</i> .....	8
5.1.4 <i>Radiated Electromagnetic Disturbance Test Data, 9kHz to 30MHz</i> .....	9
5.2 RADIATED EMISSION, 30MHZ TO 300MHZ.....	12
5.2.1 <i>E.U.T. Operation</i> .....	12
5.2.2 <i>Block Diagram of Setup</i> .....	12
5.2.3 <i>Measurement Data</i> .....	12
5.2.4 <i>Corrected Amplitude &amp; Margin Calculation</i> .....	13
5.2.5 <i>Radiated Emission Test Data</i> .....	13
<b>6 IMMUNITY TEST RESULTS.....</b>	<b>15</b>
6.1 PERFORMANCE CRITERIA .....	15
6.2 ELECTROSTATIC DISCHARGE (ESD).....	16
6.2.1 <i>E.U.T. Operation</i> .....	16
6.2.2 <i>Block Diagram of Setup</i> .....	16
6.2.3 <i>Direct Discharge Test Results</i> .....	17
6.2.4 <i>Indirect Discharge Test Results</i> .....	17
6.3 RADIO-FREQUENCY ELECTROMAGNETIC FIELDS, 80MHZ TO 1GHZ.....	18
6.3.1 <i>E.U.T. Operation</i> .....	18
6.3.2 <i>Block Diagram of Setup</i> .....	19
6.3.3 <i>Test Results</i> .....	19
<b>7 PHOTOGRAPHS – TEST SETUP .....</b>	<b>20</b>
7.1 PHOTOGRAPH – RADIATED ELECTROMAGNETIC DISTURBANCE TEST SETUP.....	20
7.2 PHOTOGRAPH – RADIATED EMISSION TEST SETUP, 30MHZ TO 300MHZ.....	20
7.3 PHOTOGRAPH – ESD IMMUNITY TEST SETUP .....	21
7.4 PHOTOGRAPH – RADIO-FREQUENCY ELECTROMAGNETIC FIELDS IMMUNITY TEST SETUP.....	21
<b>8 PHOTOGRAPHS – CONSTRUCTIONAL DETAILS.....</b>	<b>22</b>
8.1 EUT – EXTERNAL VIEW .....	22
8.2 EUT – INTERNAL VIEW .....	23





### 3 General Information

#### 3.1 General Description of E.U.T.

**Product Name** ..... : Backpack in RPET w/COB light

**Model No.** ..... : MO9969

**Remark**..... : ---

#### 3.2 Details of E.U.T.

**Technical Data**..... : DC 3V

#### 3.3 Description of Support Units

The EUT has been tested as an independent unit. MO9969 is the test sample. All tests were performed in the condition of DC 3V.

#### 3.4 Standards Applicable for Testing

The tests were performed according to following standards:

EN 55015:2013+A1:2015 Limits and methods of measurement of radio disturbance characteristics of electrical lighting and similar equipment

EN 61547:2009 Equipment for general lighting purposes — EMC immunity requirements

# WALTEK



### 3.5 Test Facility

The test facility has a test site registered with the following organizations:

- **ISED – Registration No.: 21895**

Waltek Services (Foshan) Co., Ltd. has been registered and fully described in a report filed with the Innovation, Science and Economic Development Canada (ISED). The acceptance letter from the ISED is maintained in our files. Registration ISED number: 21895, March 12, 2019

- **FCC – Registration No.: 820106**

Waltek Services (Foshan) Co., Ltd. EMC Laboratory has been registered and fully described in a report filed with the (FCC) Federal Communications Commission. The acceptance letter from the FCC is maintained in our files. Registration 820106, August 16, 2018

- **NVLAP – Lab Code: 600191-0**

Waltek Services (Foshan) Co., Ltd. EMC Laboratory is accredited by the National Voluntary Laboratory Accreditation Program (NVLAP/NIST). NVLAP Code: 600191-0.

This report must not be used by the client to claim product certification, approval, or endorsement by NVLAP, NIST, or any agency of the Federal Government.

### 3.6 Subcontracted

Whether parts of tests for the product have been subcontracted to other labs:

Yes       No

If Yes, list the related test items and lab information:

Test items: ---

Lab information: ---

### 3.7 Abnormalities from Standard Conditions

None.

# WALTEK



#### 4 Equipment Used during Test

<b>Radiated electromagnetic disturbance(9kHz to 30MHz)</b>					
<b>Item</b>	<b>Equipment</b>	<b>Manufacturer</b>	<b>Model No.</b>	<b>Serial No.</b>	<b>Calibration Status</b>
1.	EMI Test Receiver	R&S	ESCI	101178	Valid
2	Three Loops Antenna	SCHWARZBECK	HXYZ9170	213	Valid
<b>Radiated Emission</b>					
<b>Item</b>	<b>Equipment</b>	<b>Manufacturer</b>	<b>Model No.</b>	<b>Serial No.</b>	<b>Calibration Status</b>
1.	EMI Test Receiver	R&S	ESR7	101566	Valid
2.	Active Loop Antenna	SCHWARZBECK	FMZB1519B	00004	Valid
3.	Trilog Broadband Antenna	SCHWARZBECK	VULB 9162	9162-117	Valid
4.	Broad-band Horn Antenna	SCHWARZBECK	BBHA 9120 D	01561	Valid
5.	Preamplifier	Lunar E M	LNA1G18-40	20160501002	Valid
<b>ESD</b>					
<b>Item</b>	<b>Equipment</b>	<b>Manufacturer</b>	<b>Model No.</b>	<b>Serial No.</b>	<b>Calibration Status</b>
1.	ESD Simulator	TESEQ	NSG437	521	Valid
<b>Radio-frequency electromagnetic fields</b>					
<b>Item</b>	<b>Equipment</b>	<b>Manufacturer</b>	<b>Model No.</b>	<b>Serial No.</b>	<b>Calibration Status</b>
1.	RF Power Amplifier	OPHIR	5225R	1051/1712	Valid
2.	RF Power Amplifier	OPHIR	5293RE	1051/171	Valid
3.	Stacked double logarithmic periodic antenna	SCHWARZBECK	STLP9128E-SPECIAL	142	Valid
4.	Stacked double logarithmic periodic antenna	SCHWARZBECK	STLP 9149	476	Valid
5.	RF signal generator	Agilent	N5181A	MY48080720	Valid
6.	Power meter	RS	NRP6A	101133	Valid
7.	Power meter	RS	NRP6A	101134	Valid
8.	Electric field probe	Narda	EP 601	611WX70311	Valid





#### 4.1 Software List

Description	Manufacturer	Model	Version
EMI Test Software (LOOP)	FARATRONIC	EZ-EMC	CON-03A1
EMI Test Software (Radiated Emission)	FARATRONIC	EZ-EMC	RA-03A1-1
Radiated Immunity Test Software	TONSCEND	JS35-RS	V2.0.1.7

#### 4.2 Measurement Uncertainty

Test Item	Frequency Range	Uncertainty	Note
Radiated Electromagnetic Disturbance	9kHz~30MHz	±3.0dB	(1)
Radiated Emission	30MHz~1GHz	±4.1dB	(1)

(1) This uncertainty represents an expanded uncertainty expressed at approximately the 95% confidence level using a coverage factor of  $k=2$ .

#### 4.3 Special Accessories and Auxiliary Equipment

Item	Equipment	Technical Data	Manufacturer	Model No.	Serial No.
1.	/	/	/	/	/

#### 4.4 Decision Rule

Compliance or non-compliance with a disturbance limit shall be determined in the following manner.

**If  $U_{LAB}$  is less than or equal to  $U_{cispr}$ , then**

-Compliance is deemed to occur if no measured disturbance level exceeds the disturbance limit;

-Non-compliance is deemed to occur if any measured disturbance level exceeds the disturbance limit.

**If  $U_{LAB}$  is greater than  $U_{cispr}$ , then**

-Compliance is deemed to occur if no measured disturbance level, increased by  $(U_{LAB} - U_{cispr})$ , exceeds the disturbance limit;

-Non-compliance is deemed to occur if any measured disturbance level, increased by  $(U_{LAB} - U_{cispr})$ , exceeds the disturbance limit.



## 5 Emission Test Results

### 5.1 Radiated Electromagnetic Disturbance, 9kHz to 30MHz

Test Requirement ..... : EN 55015 Clause 4.4.1

Test Method ..... : EN 55015 Clause 9.1

Test Result ..... : Pass

Frequency Range ..... : 9kHz to 30MHz

Class/Severity ..... : Table 3a of EN 55015

#### 5.1.1 E.U.T. Operation

##### Operating Environment:

Temperature ..... : 24.8°C

Humidity ..... : 49.3%RH

Barometric Pressure ..... : 101.2kPa

##### EUT Operation:

Input Voltage ..... : DC 3V

Operating Mode ..... : Lighting mode

#### 5.1.2 Block Diagram of Test Setup

The Radiated Electromagnetic Disturbance (9kHz to 30MHz) test was performed in accordance with the EN 55015.

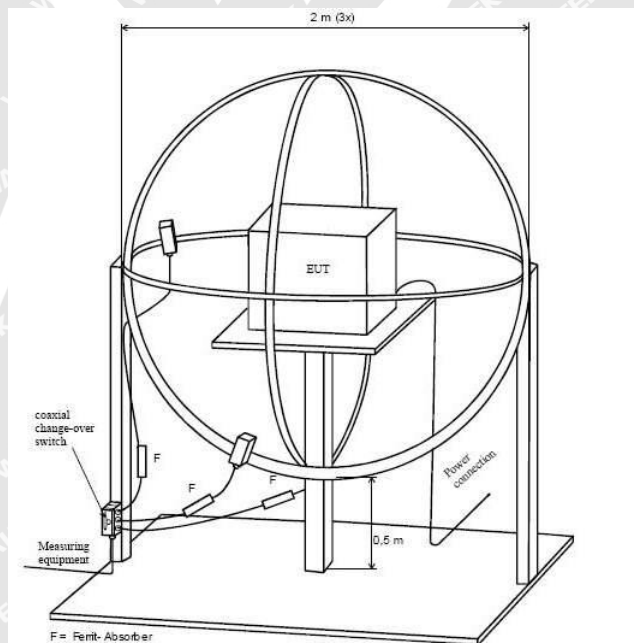

#### 5.1.3 Measurement Data

According to the data in section 5.1.4, the EUT complied with the EN 55015 standards.





### 5.1.4 Radiated Electromagnetic Disturbance Test Data, 9kHz to 30MHz

Loop X

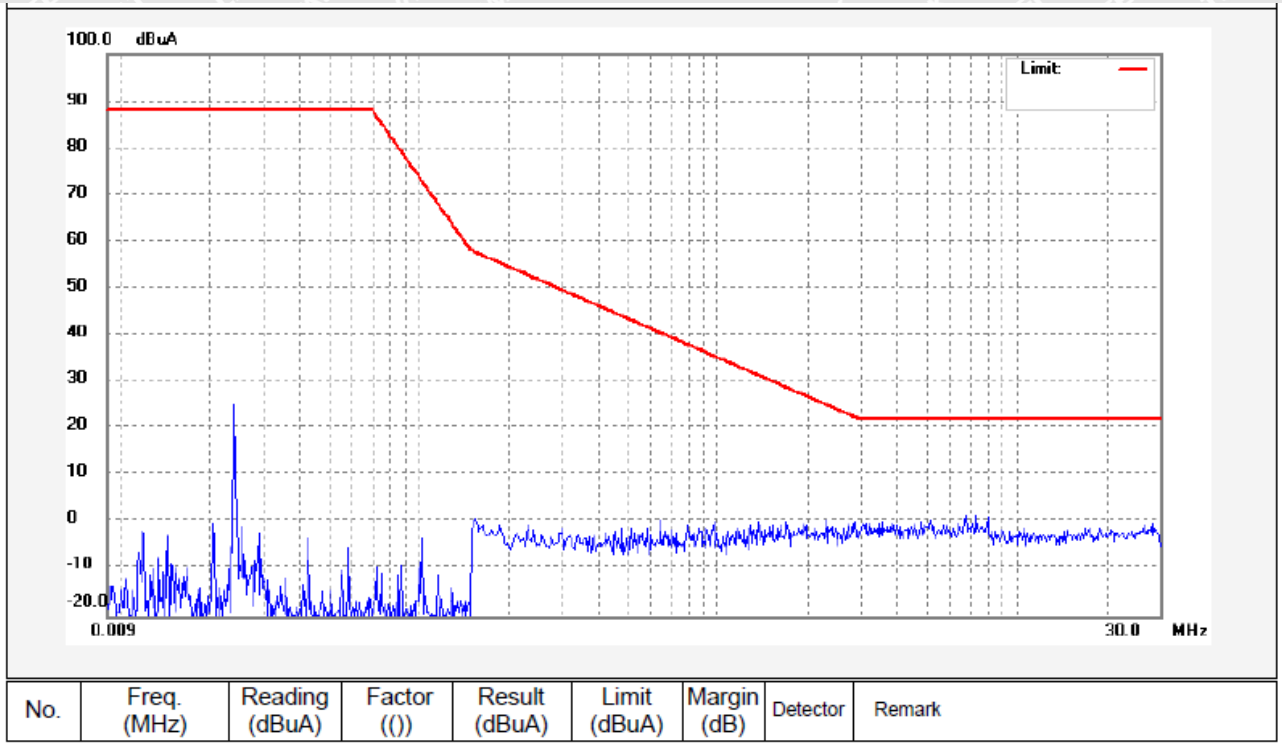



Loop Y

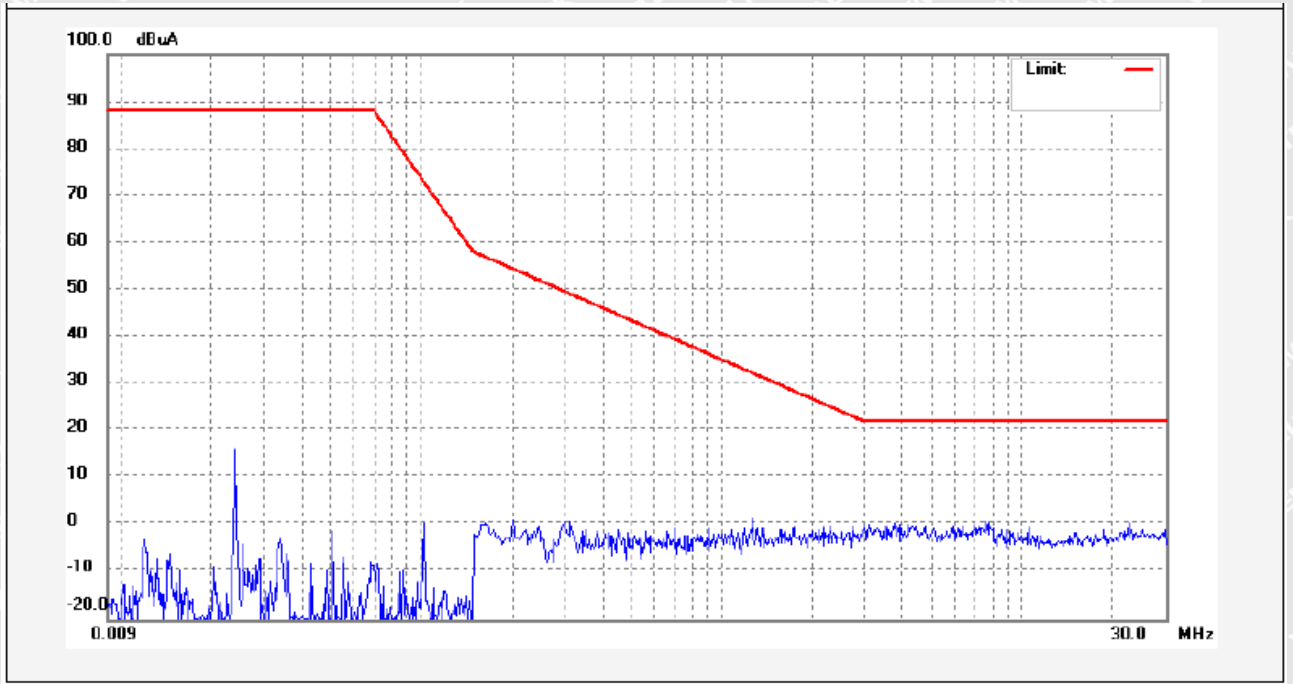

No.	Freq. (MHz)	Reading (dBuA)	Factor (())	Result (dBuA)	Limit (dBuA)	Margin (dB)	Detector	Remark
-----	-------------	----------------	-------------	---------------	--------------	-------------	----------	--------





Loop Z

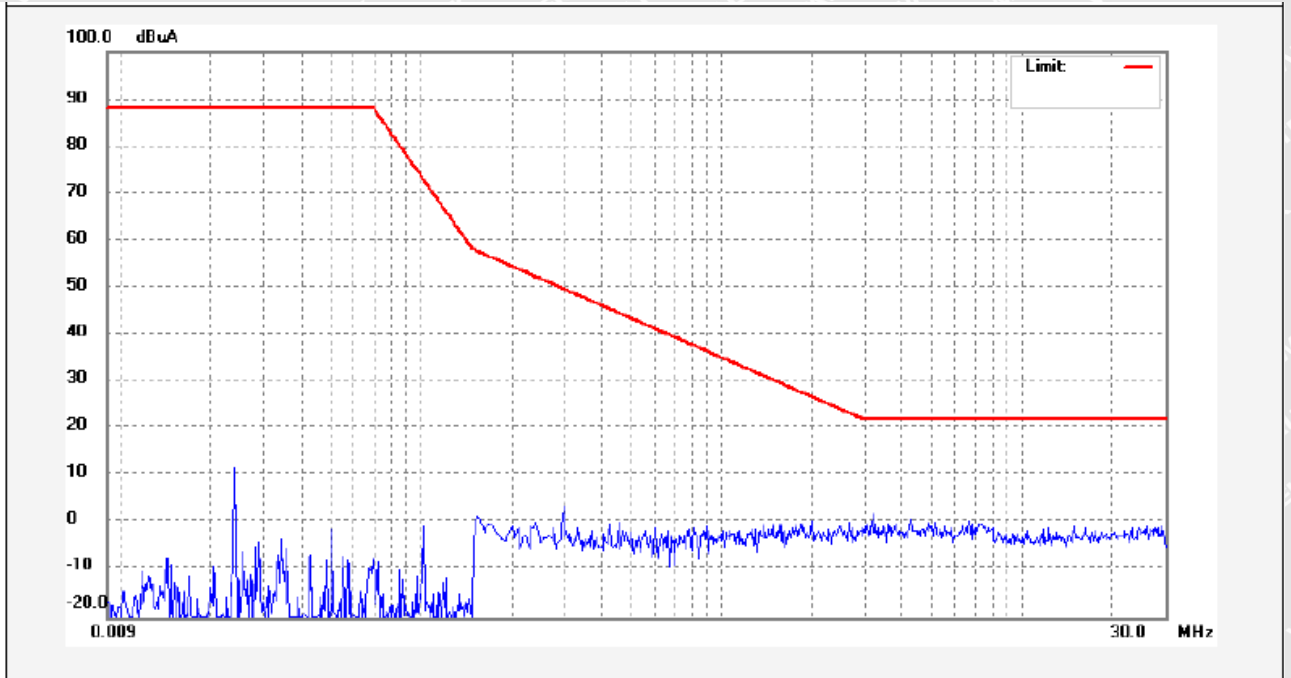

No.	Freq. (MHz)	Reading (dBuA)	Factor (())	Result (dBuA)	Limit (dBuA)	Margin (dB)	Detector	Remark
-----	-------------	----------------	-------------	---------------	--------------	-------------	----------	--------







### 5.2 Radiated Emission, 30MHz to 300MHz

- Test Requirement ..... : EN 55015 Clause 4.4.2
- Test Method ..... : Clause 10 of CISPR 22
- Test Result ..... : Pass
- Frequency Range ..... : 30MHz to 300MHz
- Class/Severity ..... : Table 3b of EN 55015

#### 5.2.1 E.U.T. Operation

##### Operating Environment:

- Temperature ..... : 23.5°C
- Humidity ..... : 48.6%RH
- Atmospheric Pressure ..... : 101.2kPa

##### EUT Operation :

- Input Voltage ..... : DC 3V
- Operating Mode ..... : Lighting mode

#### 5.2.2 Block Diagram of Setup

The Radiated Emission test was performed in the 3m Semi- Anechoic Chamber test site and accordance with CISPR16-2-3.

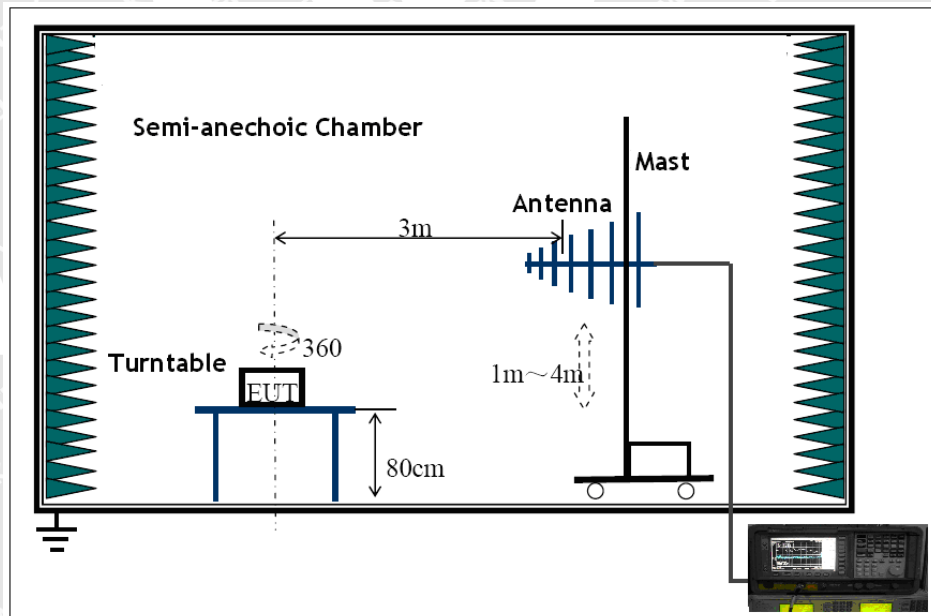

#### 5.2.3 Measurement Data

The maximised peak emissions from the EUT was scanned and measured for Horizontal & Vertical polarisation. Quasi-peak measurements were performed if peak emissions were within 6dB of the limit line.



### 5.2.4 Corrected Amplitude & Margin Calculation

The Corrected Amplitude is calculated by adding the Antenna Factor and Cable Factor, and subtracting the Amplifier Gain from the Amplitude reading. The basic equation is as follows:

$$\text{Corr. Ampl.} = \text{Indicated Reading} + \text{Corr. Factor}$$

$$\text{Corr. Factor} = \text{Antenna Factor} + \text{Cable Factor} - \text{Amplifier Gain}$$

The "Margin" column of the following data tables indicates the degree of compliance with the applicable limit. For example, a margin of -7dB means the emission is 7dB below the maximum limit.

The equation for margin calculation is as follows:

$$\text{Margin} = \text{Corr. Ampl.} - \text{Limit}$$

### 5.2.5 Radiated Emission Test Data

#### Vertical Polarization

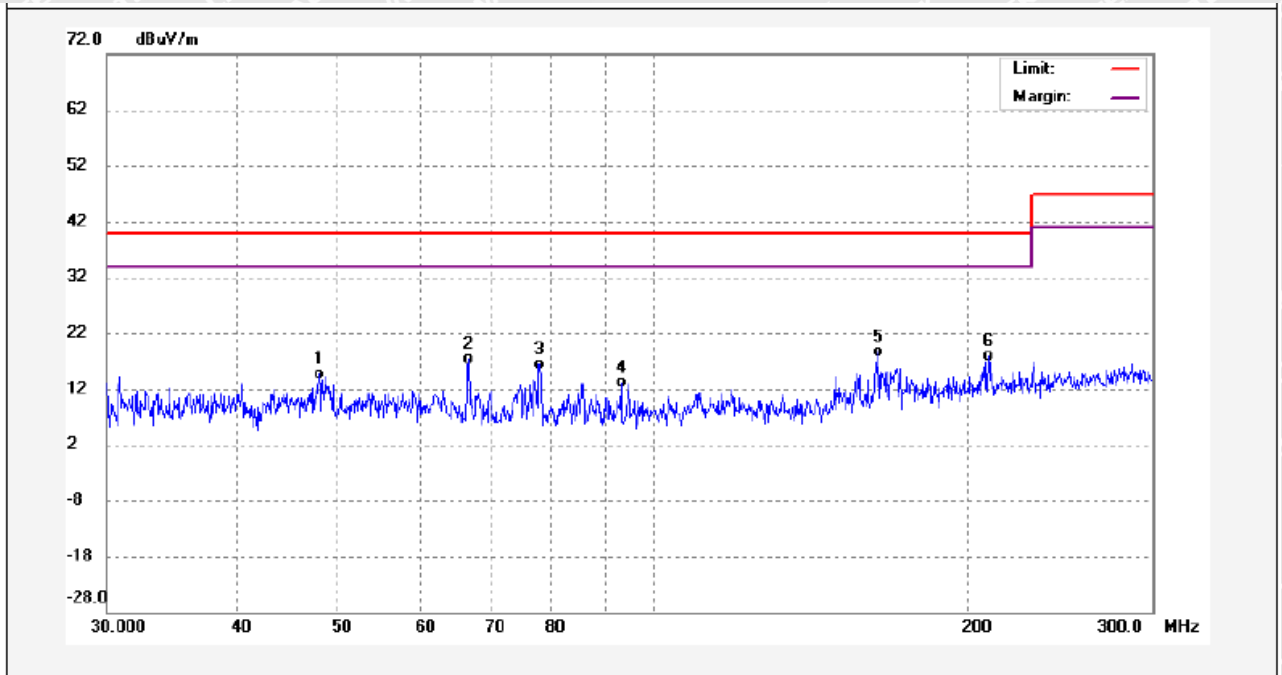

No.	Freq. (MHz)	Reading (dBuV/m)	Factor (dB)	Result (dBuV/m)	Limit (dBuV/m)	Margin (dB)	Detector	Remark
1	47.9205	1.13	13.56	14.69	40.00	-25.31	QP	
2	66.6379	6.06	11.38	17.44	40.00	-22.56	QP	
3	77.8792	6.30	10.13	16.43	40.00	-23.57	QP	
4	93.2441	1.93	11.11	13.04	40.00	-26.96	QP	
5	164.2182	5.77	12.84	18.61	40.00	-21.39	QP	
6	209.0842	3.50	14.34	17.84	40.00	-22.16	QP	



**Horizontal Polarization**

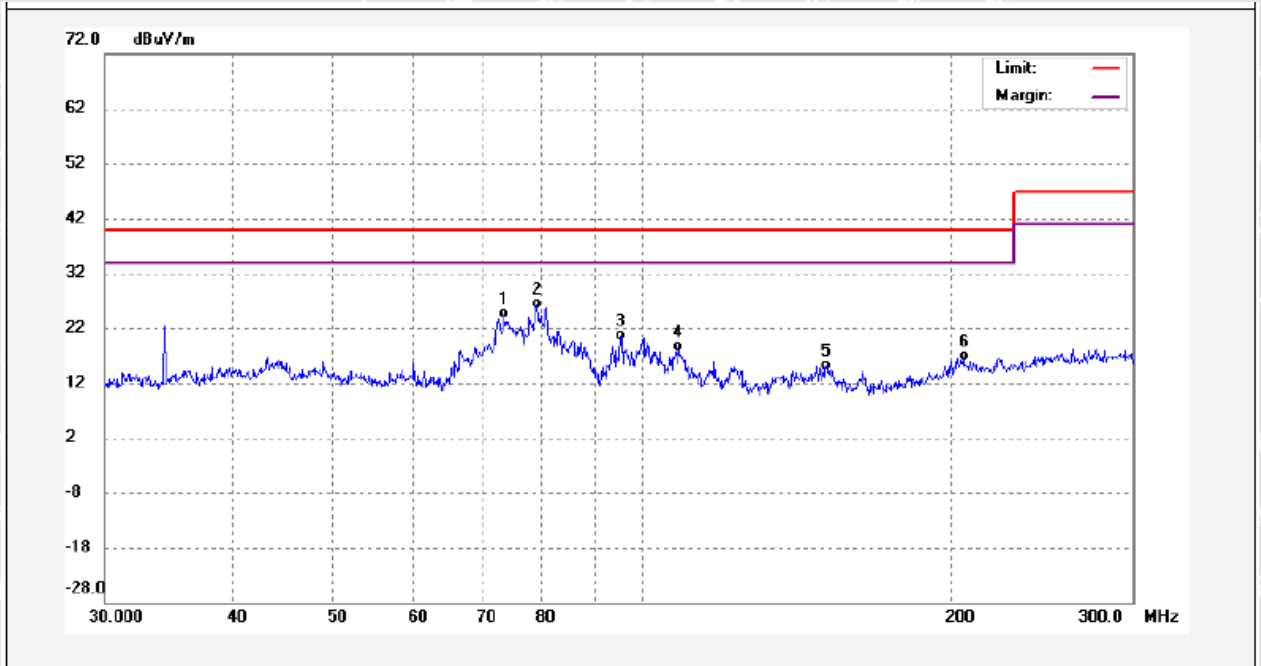

No.	Freq. (MHz)	Reading (dBuV/m)	Factor (dB)	Result (dBuV/m)	Limit (dBuV/m)	Margin (dB)	Detector	Remark
1	73.4550	15.13	9.61	24.74	40.00	-15.26	QP	
2	79.2175	16.51	9.90	26.41	40.00	-13.59	QP	
3	95.4160	8.73	11.85	20.58	40.00	-19.42	QP	
4	108.4230	6.47	12.23	18.70	40.00	-21.30	QP	
5	151.1198	5.25	9.97	15.22	40.00	-24.78	QP	
6	206.0256	3.64	13.27	16.91	40.00	-23.09	QP	







## 6 Immunity Test Results

### 6.1 Performance Criteria

**Performance criterion A:** During the test, no change of the luminous intensity shall be observed and the regulating control, if any, shall operate during the test as intended.

**Performance criterion B:** During the test, the luminous intensity may change to any value. After the test, the luminous intensity shall be restored to its initial value within 1 min. Regulating controls need not function during the test, but after the test, the mode of the control shall be the same as before the test provided that during the test no mode changing commands were given.

**Performance criterion C:** During and after the test, any change of the luminous intensity is allowed and the lamp(s) may be extinguished. After the test, within 30 min, all functions shall return to normal, if necessary by temporary interruption of the mains supply and/or operating the regulating control.



# WALTEK



## 6.2 Electrostatic Discharge (ESD)

<b>Test Requirement</b> .....	:	EN 61547
<b>Test Method</b> .....	:	IEC 61000-4-2
<b>Test Result</b> .....	:	Pass
<b>Discharge Impedance</b> .....	:	330Ω / 150pF
<b>Discharge Voltage</b> .....	:	Air Discharge: ±8kV Contact Discharge: ±4kV HCP & VCP: ±4kV
<b>Polarity</b> .....	:	Positive & Negative
<b>Number of Discharge</b> .....	:	Minimum 10 times at each test point
<b>Discharge Mode</b> .....	:	Single Discharge
<b>Discharge Period</b> .....	:	1 second minimum

### 6.2.1 E.U.T. Operation

#### Operating Environment:

<b>Temperature</b> .....	:	22.8°C
<b>Humidity</b> .....	:	47.9%RH
<b>Barometric Pressure</b> .....	:	101.1kPa

#### EUT Operation:

<b>Input Voltage</b> .....	:	DC 3V
<b>Operating Mode</b> .....	:	On mode

### 6.2.2 Block Diagram of Setup

The ESD test was performed in accordance with the IEC 61000-4-2.

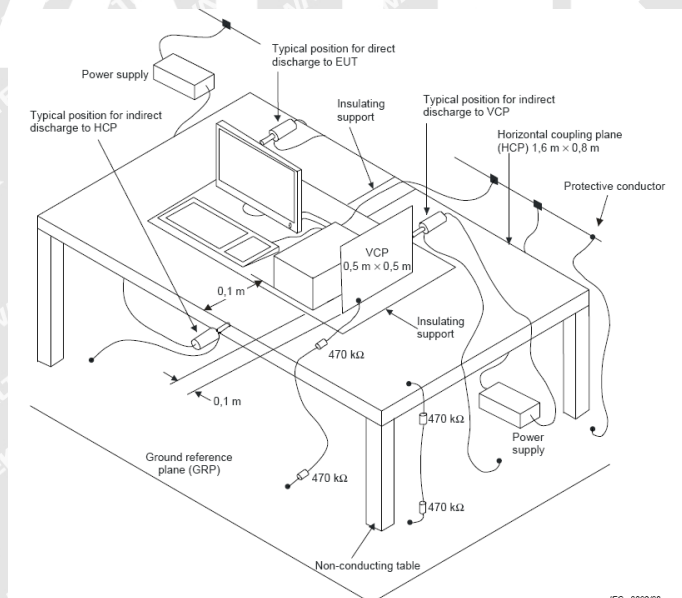



### 6.2.3 Direct Discharge Test Results

Observations: Test points: 1. All Exposed Surface & Seams;  
2. All metallic part

Direct Discharge			Test Results	
Applied Voltage (kV)	Performance Criterion	Test Point	Contact Discharge	Air Discharge
±8	B	1	N/A	Pass*
±4	B	2	Pass*	N/A

Remark:

\* During the test no deviation was detected to the selected operation mode(s)

### 6.2.4 Indirect Discharge Test Results

Observations: Test points: 1. All sides.

Indirect Discharge			Test Results	
Applied Voltage (kV)	Performance Criterion	Test Point	Horizontal Coupling	Vertical Coupling
±4	B	1	Pass*	Pass*

Remark:

\* During the test no deviation was detected to the selected operation mode(s)

# WALTEK





### 6.3 Radio-Frequency Electromagnetic Fields, 80MHz to 1GHz

Test Requirement.....	:	EN 61547
Test Method.....	:	IEC 61000-4-3
Test Result.....	:	Pass
Frequency Range.....	:	80MHz to 1GHz
Test level.....	:	3V/m
Modulation.....	:	80%, 1kHz Amplitude Modulation.
Face of EUT.....	:	Front, Back, Left, Right
Antenna polarisation.....	:	Horizontal & Vertical
Test Distance.....	:	3m

#### 6.3.1 E.U.T. Operation

##### Operating Environment:

Temperature.....	:	23.7°C
Humidity.....	:	54.5%RH
Barometric Pressure.....	:	101.9kPa

##### EUT Operation:

Input Voltage.....	:	DC 3V
Operating Mode.....	:	On mode

# WALTEK



### 6.3.2 Block Diagram of Setup

The Radio-Frequency Electromagnetic Fields Immunity test was performed in accordance with the IEC 61000-4-3.

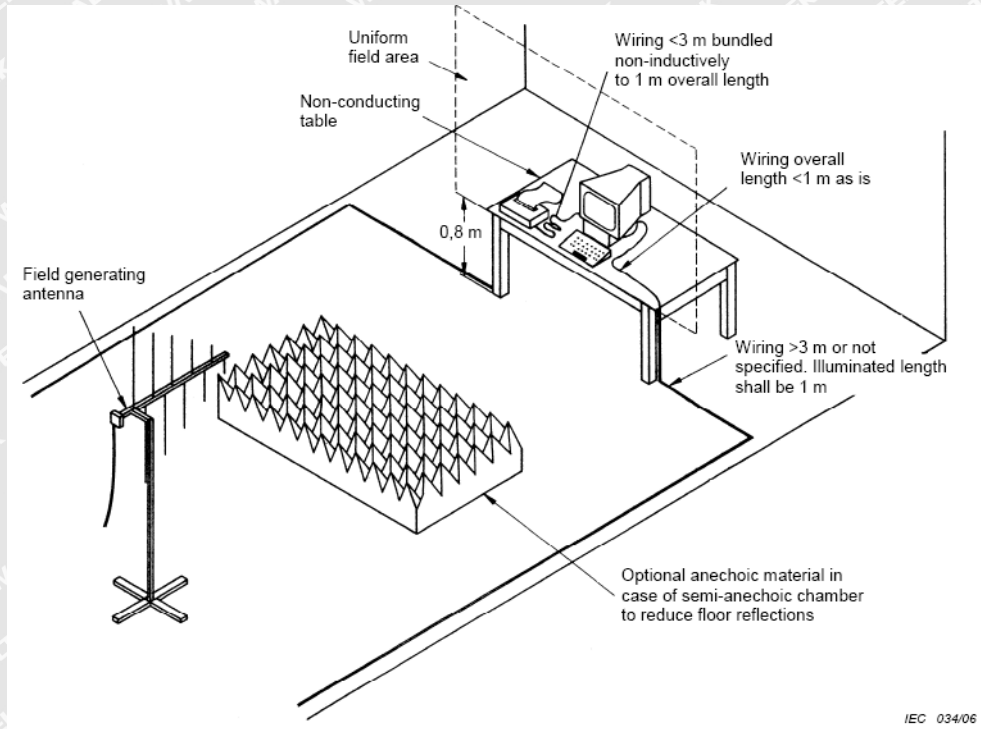

### 6.3.3 Test Results

Frequency	Face of EUT	Antenna polarisation	Test Level	Step Size	Dwell Time	Performance Criterion	Result
80 to 1000MHz	Front, Back, Left, Right	Horizontal	3V/m	1%	1s	A	Pass*
80 to 1000MHz	Front, Back, Left, Right	Vertical	3V/m	1%	1s	A	Pass*

Remark:

\* During the test no deviation was detected to the selected operation mode(s)



## 7 Photographs – Test Setup

### 7.1 Photograph – Radiated Electromagnetic Disturbance Test Setup



### 7.2 Photograph – Radiated Emission Test Setup, 30MHz to 300MHz







### 7.3 Photograph – ESD Immunity Test Setup



### 7.4 Photograph – Radio-Frequency Electromagnetic Fields Immunity Test Setup

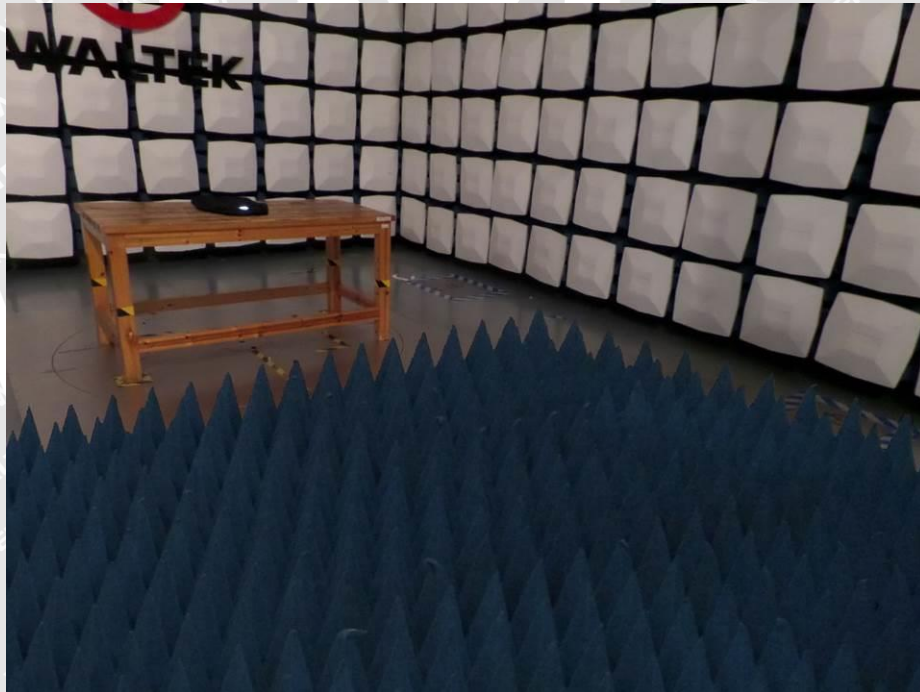



## 8 Photographs – Constructional Details

### 8.1 EUT – External View

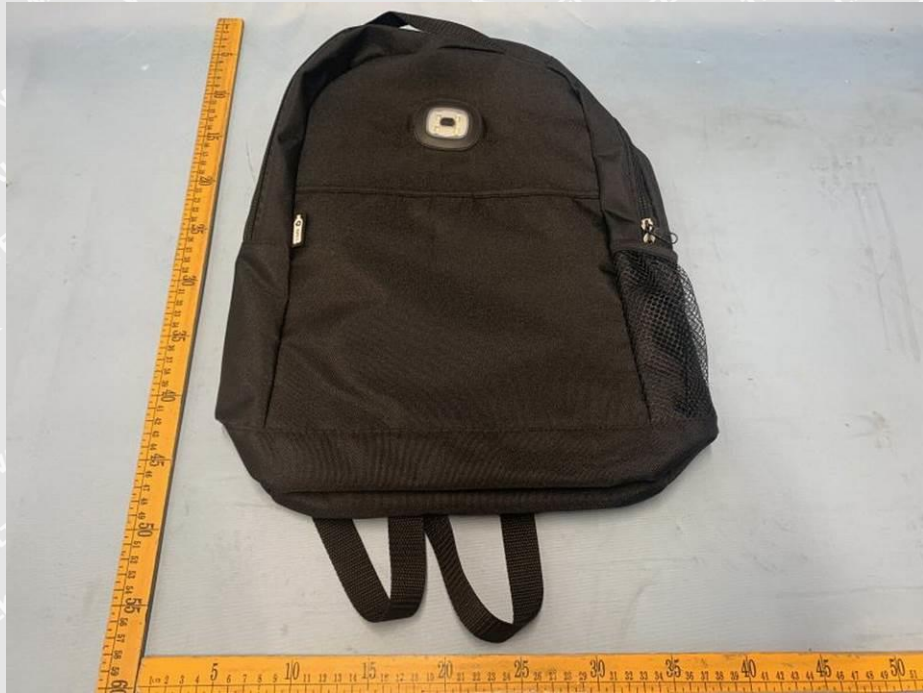





### 8.2 EUT – Internal View

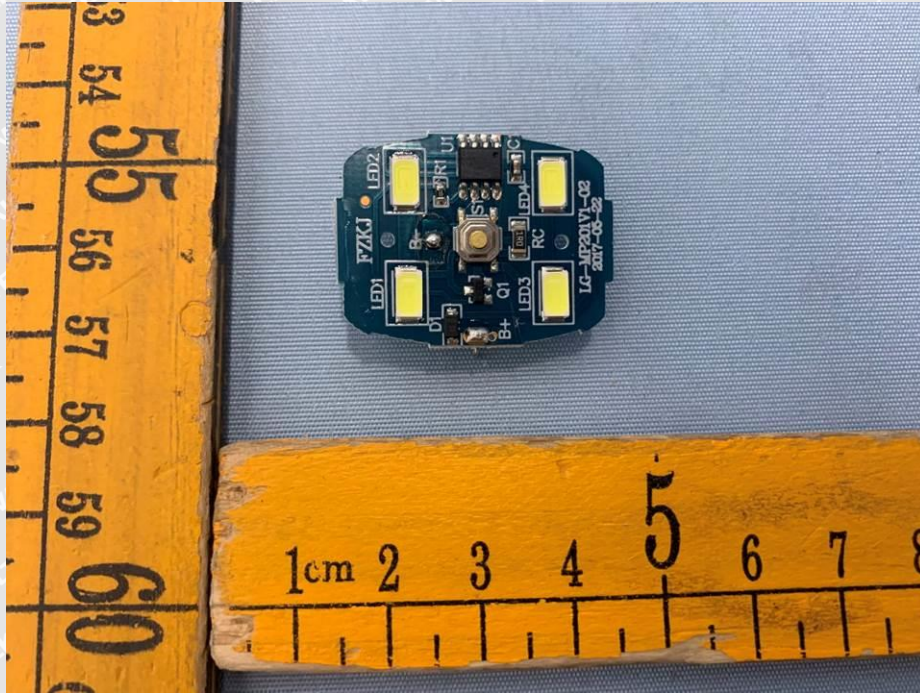

===== End of Report =====