

# Test Report

Report No.: AGC03778181201-005S1

Date: Dec.21, 2018

Page 1 of 10

Applicant: MID OCEAN BRANDS B.V  
Address: 7/F, Kings Tower, 111 King Lam Street, Cheung Sha Wan, Kowloon, Hong Kong

## Report on the submitted samples said to be:

Sample Name : See Sample Information  
Model : See Sample Information  
Manufacturers : 101191  
Sample Receiving Date : Dec.03, 2018  
Testing Period : Dec.03, 2018 to Dec.18, 2018

Test Method : Please refer to next page(s).

Test Result : Please refer to next page(s).

## Test Requested

1.ISO 12312-1:2013+A1:2015, excluding:  
- Clause 12 Information and labeling

## Conclusion

Pass



Approved by: Jay. Liu

Liu Jinliang, Jay.Liu

Laboratory Supervisor



The results shown in this test report refer only to the sample(s) tested unless otherwise stated and the sample(s) are retained for 30 days only. The document is issued by AGC, this document cannot be reproduced except in full with our prior written permission. The more details and the authenticity of the report will be confirmed at <http://www.agc-cert.com>.

# Test Report

**Report No.: AGC03778181201-005S1**

Date: Dec.21, 2018

Page 2 of 10

**1.Tests Conducted Summary:**
**(1) Requirements for Sunglasses**

Test standard: - ISO 12312-1:2013+A1:2015      Eye and face protection — Sunglasses and related eyewear  
 — Part 1: Sunglasses for general use  
 - ISO 12311:2013      Personal protective equipment —Test methods for  
 Sunglasses and related eyewear

Note: The applicant's attention was drawn that the manufacturer should not use the frame materials which are known to cause irritation, allergic or toxic reaction during wear in a normal state of health against significant proportion of users.

CLAUSES	REQUIREMENTS		RESULT
4	Construction and materials		
4.1	Construction		P
4.2	Filter material and surface quality		P
4.3	Physiological compatibility (Nickel Release)		NA
5	Transmittance		
5.2	Transmittance and filter categories	Filter categories	Cat.3
		UV requirements	P
5.3	General transmittance requirements		
5.3.1	Uniformity of luminous transmittance		P
5.3.2	Requirements for road use and driving	5.3.2.2 Spectral transmittance	P
		5.3.2.3 Detection of signal lights	P
		5.3.2.4 Driving in twilight or at night	NA
5.3.3	Wide angle scattering		P
5.3.4	Additional transmittance requirements for specific filter types	5.3.4.1 Photochromic filters	NA
		5.3.4.2 Polarizing filters	NA
		5.3.4.3 Gradient filters	NA
6	Refractive power		
6.1	Spherical and astigmatic power		P
6.2	Local variations in refractive power		P
6.3	Prism imbalance (relative prism error)		P

The results shown in this test report refer only to the sample(s) tested unless otherwise stated and the sample(s) are retained for 30 days only. The document is issued by AGC, this document cannot be reproduced except in full with our prior written permission. The more details and the authenticity of the report will be confirmed at <http://www.agc-cert.com>.





# Test Report

**Report No.: AGC03778181201-005S1**

Date: Dec.21, 2018

Page 3 of 10

CLAUSES	REQUIREMENTS	RESULT
7	Robustness	
7.1	Minimum robustness of filters	P
7.2	Frame deformation and retention of filters	P
8	Resistance to solar radiation	P
9	Resistance to ignition	P
11	Protective requirements	
11.1	Coverage area	P
12	Information and labeling	
12.1	Information to be supplied with each pair of sunglasses	NR
12.2	Additional information	NR

**Remark:** P=Pass; F=Fail; NA=Not Applicable; NR=Not Require; X=Checked; Cat.=Category;

## Test Results

### Construction—Clause 4.1 and Filter material and surface quality —Clause 4.2

Sample Number	Defects				Comment	Result
	Construction		Filter material and surface quality			
	Observed	Absent	Observed	Absent		
1		X		X	--	P

#### Requirements:

- Construction shall be smooth and without sharp projections;
- Filter material and surface quality: Except in a marginal area 5 mm wide, sunglass filters shall have no material or machining defects within an area of 30mm diameter around the reference point that may impair vision, e.g. bubbles, scratches, inclusions, dull spots, pitting, mould marks, notches, reinforced points, specks, beads, water specks, pocking, gas inclusions, splintering, cracks, polishing defects or undulations.

The results shown in this test report refer only to the sample(s) tested unless otherwise stated and the sample(s) are retained for 30 days only. The document is issued by AGC, this document cannot be reproduced except in full with our prior written permission. The more details and the authenticity of the report will be confirmed at <http://www.agc-cert.com>.



# Test Report

**Report No.: AGC03778181201-005S1**

Date: Dec.21, 2018

Page 4 of 10

**Transmittance and filter categories —Clause 5.2**

Sample No.: 1				
Test Items	Requirements	Left	Right	Result(s)
Luminous transmittance $\tau_v$ (380~780)nm (%)	For Cat. 0: 80.0~100	11.6	11.9	Cat.3
	For Cat. 1: 43.0~80.0			
	For Cat. 2: 18.0~43.0			
	For Cat. 3: 8.0~18.0			
	For Cat. 4: 3.0~8.0			
Filter categories	Claimed Cat.: (Not Provided)			
$\tau_{SUVB}$ (280~315)nm (%)	For Cat.0, 1: $\leq 0.05\tau_v$ For Cat.2: 1.0% absolute or $0.05\tau_v$ whichever is greater; For Cat.3, 4: 1.0% absolute	0.0	0.0	P
$\tau_{SUVA}$ (315~380)nm (%)	For Cat.0, 1: $\leq \tau_v$ ; For Cat.2, 3: $\leq 0.5\tau_v$ For Cat.4: 1.0% absolute or $0.25\tau_v$ whichever is greater	0.0	0.1	P
$\tau_{sb}$ (380~500)nm (%)	---	7.6	7.8	Only Ref.

Measurement Uncertainty (if necessary):

The results shown in this test report refer only to the sample(s) tested unless otherwise stated and the sample(s) are retained for 30 days only. The document is issued by AGC, this document cannot be reproduced except in full with our prior written permission. The more details and the authenticity of the report will be confirmed at <http://www.agc-cert.com>.

**AGC**
**Attestation of Global Compliance Std. & Tech.**
**No.18 C**  
 Tel: +86-755 8358 3833 Fax: +86-755 2531 6612 E-mail: agc01@agc-cert.com 400 089 2118  
 Add: Building 2, No.171, Meihua Road, Shangmeilin, Futian District, Shenzhen, Guangdong China



# Test Report

**Report No.: AGC03778181201-005S1**

Date: Dec.21, 2018

Page 5 of 10

**Uniformity of luminous transmittance — Clause 5.3.1**

Sample No.: 1				
Test Items	Requirements	Left	Right	Result(s)
Difference within filter (%) (relative to higher value)	The relative difference in the luminous transmittance value shall not be greater than 10%, except for Cat. 4 where it shall not be greater than 20%	5.7	7.8	P
Difference with mounted filters (relative to higher value)	The relative difference between the luminous transmittance value of the visual center for right and left eye shall not exceed 15%	2.5		P

Measurement Uncertainty (if necessary):

**Requirements for road use and driving — Clause 5.3.2**

Sample No.: 1				
Test Items	Requirements	Left	Right	Result(s)
Categories	Filters suitable for road use and driving shall be categories 0, 1, 2 or 3	Cat.3	Cat.3	P
Spectral transmittance (475~650)nm (%)	$\cong 0.2\tau_v$	9.7 ( $0.2\tau_v=2.3$ )	9.8 ( $0.2\tau_v=2.4$ )	P
Red Signal	$\cong 0.80$	1.248	1.256	P
Yellow Signal	$\cong 0.60$	1.075	1.079	
Green Signal	$\cong 0.60$	0.963	0.960	
Blue Signal	$\cong 0.60$	0.932	0.925	
Driving in twilight or at night(%)	$\tau_v \cong 75\%$	11.6	11.9	NA

Measurement Uncertainty (if necessary):

The results shown in this test report refer only to the sample(s) tested unless otherwise stated and the sample(s) are retained for 30 days only. The document is issued by AGC, this document cannot be reproduced except in full with our prior written permission. The more details and the authenticity of the report will be confirmed at <http://www.agc-cert.com>.



# Test Report

**Report No.: AGC03778181201-005S1**

Date: Dec.21, 2018

Page 6 of 10

**Wide angle scattering—Clause 5.3.3**

Sample Number	Wide angle scattering(%)		Result
	Left	Right	
1	2.3	2.2	P

**Requirements:**

The wide angle scattering of the filters in the condition as supplied by the manufacturer shall not exceed the value of 3 %.

Measurement Uncertainty (if necessary):

**Refractive power—Clause 6**

Sample No.: 1					
Test Items	Requirements	Left	Right	Result(s)	
Spherical Power (D)	$\pm 0.12D$	+0.02	+0.01	P	
	The difference between the spherical powers shall not exceed 0.18 D;	0.01		P	
Astigmatic Power (D)	$\cong 0.12D$	0.00	0.00	P	
Local variations in refractive power (D)	Spherical Power	$\pm 0.12D$	1*	+0.01	P
		2*	+0.02	+0.02	
		3*	+0.01	+0.02	
		4*	+0.02	+0.01	
	Astigmatic Power	$\cong 0.12D$	1*	0.01	P
		2*	0.02	0.01	
		3*	0.01	0.01	
		4*	0.00	0.01	
Prism imbalance (cm/m)	Horizontal	Base Out: <1.00	--		
		Base In: <0.25	0.16		
	Vertical	<0.25	0.22		

Measurement Uncertainty (if necessary):

 The results shown in this test report refer only to the sample(s) tested unless otherwise stated and the sample(s) are retained for 30 days only. The document is issued by AGC, this document cannot be reproduced except in full with our prior written permission. The more details and the authenticity of the report will be confirmed at <http://www.agc-cert.com>.

## No.18 C



# Test Report

Report No.: AGC03778181201-005S1

Date: Dec.21, 2018

Page 7 of 10

Note: \* See figure:

Key: A =Reference points

X = Measure point

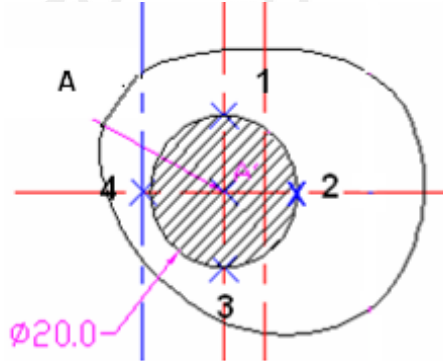

Figure: Measuring Location of refractive power

## Minimum robustness of filters — Clause 7.1

Sample Number	Defects		Comment	Result
	Observed	Absent		
1		X	--	P

Requirements:

None of the following defects shall appear on filters :

1. Filter fracture;
2. Filter deformation;

## Frame deformation and retention of filters — Clause 7.2

Sample Number	Boxed center Distance C (mm)	Residual Deformation X (mm)	Deformation Percentage $\Phi$ (%)	Structure		Lens Retention		Result
				Pass	Fail	Pass	Fail	
1	73.00	0.06	0.1	X		X		P

Requirements:

1. Be permanently deformed from its original configuration by not more than 2% of the distance C.,  
Deformation percentage $\Phi$ ; Calculation:  $\Phi$  (%) =  $X/C \times 100$
2. No fracture or crack at any point ;
3. No filter shall be displaced from the frame.

Measurement Uncertainty (if necessary):

The results shown in this test report refer only to the sample(s) tested unless otherwise stated and the sample(s) are retained for 30 days only. The document is issued by AGC, this document cannot be reproduced except in full with our prior written permission. The more details and the authenticity of the report will be confirmed at <http://www.agc-cert.com>.



# Test Report

**Report No.: AGC03778181201-005S1**

Date: Dec.21, 2018

Page 8 of 10

**Resistance to Radiation — Clause 8**

Sample No.: 1						
Test Items		Requirements		Left	Right	Result(s)
The relative change of luminous transmittance		For Cat. 0: <math>\leq \pm 3\%</math>	Before exposure	11.6	11.9	P
		For Cat. 1: <math>\leq \pm 5\%</math>	After exposure	11.6	11.8	
		For Cat. 2: <math>\leq \pm 8\%</math>	Difference	0.0	-0.8	
Wide angle scattering		After exposure, the value of wide angle scattering shall not exceed the limit value of 3%;		2.3	2.3	P
Requirements for the ultraviolet spectral range for $\tau_v$ (%)	$\tau_{SUVB}$ (280~315) nm (%)	For Cat. 0,1: $\leq 0.05\tau_v$ For Cat. 2: 1.0% absolute or $0.05\tau_v$ whichever is greater; For Cat. 3, 4: 1.0% absolute		0.0	0.0	P
	$\tau_{SUVA}$ (315~380) nm (%)	For Cat. 0,1: $\leq \tau_v$ ; For Cat. 2, 3: $\leq 0.5\tau_v$ For Cat. 4: 1.0% absolute or $0.25\tau_v$ whichever is greater;		0.0	0.0	P

Measurement Uncertainty (if necessary):

**Ignition—Clause 9**

Sample Number	Continued combustion		Comment	Result
	Yes	No		
1		X	--	P

**Requirements:**

The filters and frame shall be no continued combustion after withdrawal of the test rod.

The results shown in this test report refer only to the sample(s) tested unless otherwise stated and the sample(s) are retained for 30 days only. The document is issued by AGC, this document cannot be reproduced except in full with our prior written permission. The more details and the authenticity of the report will be confirmed at <http://www.agc-cert.com>.





# Test Report

**Report No.: AGC03778181201-005S1**

Date: Dec.21, 2018

Page 9 of 10

**Coverage area — Clause 11.1**

Sample Number	Type (Adult/Children)	Test Position	Coverage area		Comment	Result
			Pass	Fail		
1	Adults	Left	X		--	P
		Right	X		--	P

**Requirements:**

- Adults' sunglasses shall cover two ellipses of horizontal diameter of 40mm and a vertical diameter of 28mm, the centres of which are separated 64mm and symmetrically placed on either side of the centre of the nose bridge of the frame.
- Children's sunglasses shall cover two ellipses of horizontal diameter of 34mm and a vertical diameter of 24mm, the centres of which are separated 54mm and symmetrically placed on either side of the centre of the nose bridge of the frame.

**Sample description:**

1	Blue lens
---	-----------

The results shown in this test report refer only to the sample(s) tested unless otherwise stated and the sample(s) are retained for 30 days only. The document is issued by AGC, this document cannot be reproduced except in full with our prior written permission. The more details and the authenticity of the report will be confirmed at <http://www.agc-cert.com>.



# Test Report

Report No.: AGC03778181201-005S1

Date: Dec.21, 2018

Page 10 of 10

## Sample Information

Model	Sample Name
MO9034-37	plastic bi-color outer in Black and inner in Blue with blue mirror lens
MO9521-37	Stainless iron silver color with blue mirror lens (blue pouch)
MO8652-04	plastic Transparent frosty white frame and blue leg with blue mirror lens

This report is to supersede the report with No.: AGC03778181201-005 dated on Dec.18,2018.

## The photo of the sample



**AGC03778181201-005S1**

AGC authenticate the photo on original report only

\*\*\* End of Report\*\*\*

The results shown in this test report refer only to the sample(s) tested unless otherwise stated and the sample(s) are retained for 30 days only. The document is issued by AGC, this document cannot be reproduced except in full with our prior written permission. The more details and the authenticity of the report will be confirmed at <http://www.agc-cert.com>.

**AGC**

Attestation of Global Compliance Std. & Tech.

Tel: +86-755 8358 3833 Fax: +86-755 2531 6612 E-mail: agc01@agc-cert.com 400 089 2118  
Add: Building 2, No. 171, Meihua Road, Shangmeilin, Futian District, Shenzhen, Guangdong China

**No.18 C**



# Test Report

Report No.: AGC03778181201-006S2

Date: Jan.14, 2019

Page 1 of 10

Applicant: MID OCEAN BRANDS B.V  
Address: 7/F, Kings Tower, 111 King Lam Street, Cheung Sha Wan, Kowloon, Hong Kong

**Report on the submitted samples said to be:**

Sample Name : See Sample Information  
Model : See Sample Information  
Manufacturers : 101191  
Sample Receiving Date : Dec.03, 2018  
Testing Period : Dec.03, 2018 to Dec.18, 2018

**Test Method** : Please refer to next page(s).

**Test Result** : Please refer to next page(s).

**Test Requested**

1.ISO 12312-1:2013+A1:2015, excluding:  
- Clause 12 Information and labeling

**Conclusion**

**Pass**



Approved by: Jay. Liu

Liujiuliang, Jay.Liu  
Laboratory Supervisor



The results shown in this test report refer only to the sample(s) tested unless otherwise stated and the sample(s) are retained for 30 days only. The document is issued by AGC, this document cannot be reproduced except in full with our prior written permission. The more details and the authenticity of the report will be confirmed at <http://www.agc-cert.com>.

# Test Report

**Report No.: AGC03778181201-006S2**

Date: Jan.14, 2019

Page 2 of 10

**1.Tests Conducted Summary:**
**(1) Requirements for Sunglasses**

Test standard: - ISO 12312-1:2013+A1:2015  - ISO 12311:2013	Eye and face protection — Sunglasses and related eyewear — Part 1: Sunglasses for general use  Personal protective equipment —Test methods for Sunglasses and related eyewear
---	---

Note: The applicant's attention was drawn that the manufacturer should not use the frame materials which are known to cause irritation, allergic or toxic reaction during wear in a normal state of health against significant proportion of users.

CLAUSES	REQUIREMENTS		RESULT
4	Construction and materials		
4.1	Construction		P
4.2	Filter material and surface quality		P
4.3	Physiological compatibility (Nickel Release)		NA
5	Transmittance		
5.2	Transmittance and filter categories	Filter categories	Cat.3
		UV requirements	P
5.3	General transmittance requirements		
5.3.1	Uniformity of luminous transmittance		P
5.3.2	Requirements for road use and driving	5.3.2.2 Spectral transmittance	P
		5.3.2.3 Detection of signal lights	P
		5.3.2.4 Driving in twilight or at night	NA
5.3.3	Wide angle scattering		P
5.3.4	Additional transmittance requirements for specific filter types	5.3.4.1 Photochromic filters	NA
		5.3.4.2 Polarizing filters	NA
		5.3.4.3 Gradient filters	NA
6	Refractive power		
6.1	Spherical and astigmatic power		P
6.2	Local variations in refractive power		P
6.3	Prism imbalance (relative prism error)		P

The results shown in this test report refer only to the sample(s) tested unless otherwise stated and the sample(s) are retained for 30 days only. The document is issued by AGC, this document cannot be reproduced except in full with our prior written permission. The more details and the authenticity of the report will be confirmed at <http://www.agc-cert.com>.





# Test Report

**Report No.: AGC03778181201-006S2**

Date: Jan.14, 2019

Page 3 of 10

CLAUSES	REQUIREMENTS	RESULT
7	Robustness	
7.1	Minimum robustness of filters	P
7.2	Frame deformation and retention of filters	P
8	Resistance to solar radiation	P
9	Resistance to ignition	P
11	Protective requirements	
11.1	Coverage area	P
12	Information and labeling	
12.1	Information to be supplied with each pair of sunglasses	NR
12.2	Additional information	NR

**Remark:** P=Pass; F=Fail; NA=Not Applicable; NR=Not Require; X=Checked; Cat.=Category;

## Test Results

### Construction—Clause 4.1 and Filter material and surface quality —Clause 4.2

Sample Number	Defects				Comment	Result
	Construction		Filter material and surface quality			
	Observed	Absent	Observed	Absent		
1		X		X	--	P

#### Requirements:

- Construction shall be smooth and without sharp projections;
- Filter material and surface quality: Except in a marginal area 5 mm wide, sunglass filters shall have no material or machining defects within an area of 30mm diameter around the reference point that may impair vision, e.g. bubbles, scratches, inclusions, dull spots, pitting, mould marks, notches, reinforced points, specks, beads, water specks, pocking, gas inclusions, splintering, cracks, polishing defects or undulations.

The results shown in this test report refer only to the sample(s) tested unless otherwise stated and the sample(s) are retained for 30 days only. The document is issued by AGC, this document cannot be reproduced except in full with our prior written permission. The more details and the authenticity of the report will be confirmed at <http://www.agc-cert.com>.



# Test Report

**Report No.: AGC03778181201-006S2**

Date: Jan.14, 2019

Page 4 of 10

**Transmittance and filter categories —Clause 5.2**

Sample No.: 1				
Test Items	Requirements	Left	Right	Result(s)
Luminous transmittance $\tau_v$ (380~780)nm (%)	For Cat. 0: 80.0~100	17.9	18.5	Cat.3
	For Cat. 1: 43.0~80.0			
	For Cat. 2: 18.0~43.0			
	For Cat. 3: 8.0~18.0			
	For Cat. 4: 3.0~8.0			
Filter categories	Claimed Cat.: (Not Provided)			
$\tau_{SUVB}$ (280~315)nm (%)	For Cat.0, 1: $\leq 0.05\tau_v$ For Cat.2: 1.0% absolute or $0.05\tau_v$ whichever is greater; For Cat.3, 4: 1.0% absolute	0.0	0.0	P
$\tau_{SUVA}$ (315~380)nm (%)	For Cat.0, 1: $\leq \tau_v$ ; For Cat.2, 3: $\leq 0.5\tau_v$ For Cat.4: 1.0% absolute or $0.25\tau_v$ whichever is greater	0.0	0.1	P
$\tau_{sb}$ (380~500)nm (%)	---	14.4	14.2	Only Ref.

Measurement Uncertainty (if necessary):

The results shown in this test report refer only to the sample(s) tested unless otherwise stated and the sample(s) are retained for 30 days only. The document is issued by AGC, this document cannot be reproduced except in full with our prior written permission. The more details and the authenticity of the report will be confirmed at <http://www.agc-cert.com>.

**Attestation of Global Compliance Std. & Tech.**
**No.18 C**  
 Tel: +86-755 8358 3833 Fax: +86-755 2531 6612 E-mail: agc01@agc-cert.com 400 089 2118  
 Add: Building 2, No.171, Meihua Road, Shangmeilin, Futian District, Shenzhen, Guangdong China



# Test Report

**Report No.: AGC03778181201-006S2**

Date: Jan.14, 2019

Page 5 of 10

**Uniformity of luminous transmittance — Clause 5.3.1**

Sample No.: 1				
Test Items	Requirements	Left	Right	Result(s)
Difference within filter (%) (relative to higher value)	The relative difference in the luminous transmittance value shall not be greater than 10%, except for Cat. 4 where it shall not be greater than 20%	3.8	2.0	P
Difference with mounted filters (relative to higher value)	The relative difference between the luminous transmittance value of the visual center for right and left eye shall not exceed 15%	3.0		P

Measurement Uncertainty (if necessary):

**Requirements for road use and driving — Clause 5.3.2**

Sample No.: 1				
Test Items	Requirements	Left	Right	Result(s)
Categories	Filters suitable for road use and driving shall be categories 0, 1, 2 or 3	Cat.3	Cat.3	P
Spectral transmittance (475~650)nm (%)	$\cong 0.2\tau_v$	6.4 ( $0.2\tau_v=2.0$ )	5.8 ( $0.2\tau_v=2.0$ )	P
Red Signal	$\cong 0.80$	0.962	0.986	P
Yellow Signal	$\cong 0.60$	1.008	1.023	
Green Signal	$\cong 0.60$	1.042	1.030	
Blue Signal	$\cong 0.60$	0.875	0.851	
Driving in twilight or at night(%)	$\tau_v \cong 75\%$	10.1	9.8	NA

Measurement Uncertainty (if necessary):

The results shown in this test report refer only to the sample(s) tested unless otherwise stated and the sample(s) are retained for 30 days only. The document is issued by AGC, this document cannot be reproduced except in full with our prior written permission. The more details and the authenticity of the report will be confirmed at <http://www.agc-cert.com>.



# Test Report

**Report No.: AGC03778181201-006S2**

Date: Jan.14, 2019

Page 6 of 10

**Wide angle scattering—Clause 5.3.3**

Sample Number	Wide angle scattering(%)		Result
	Left	Right	
1	2.2	2.2	P

Requirements:

The wide angle scattering of the filters in the condition as supplied by the manufacturer shall not exceed the value of 3 %.

Measurement Uncertainty (if necessary):

**Refractive power—Clause 6**

Sample No.: 1					
Test Items	Requirements	Left	Right	Result(s)	
Spherical Power (D)	$\pm 0.12D$	-0.02	-0.03	P	
	The difference between the spherical powers shall not exceed 0.18 D;	0.01		P	
Astigmatic Power (D)	$\cong 0.12D$	0.00	0.00	P	
Local variations in refractive power (D)	Spherical Power	$\pm 0.12D$	1*	-0.02	P
		2*	-0.03	-0.02	
		3*	-0.02	-0.01	
		4*	-0.01	-0.03	
	Astigmatic Power	$\cong 0.12D$	1*	0.02	P
		2*	0.02	0.01	
		3*	0.00	0.02	
		4*	0.01	0.02	
Prism imbalance (cm/m)	Horizontal	Base Out: <1.00	--		
		Base In: <0.25	0.03		
	Vertical	<0.25	0.03		

Measurement Uncertainty (if necessary):

 The results shown in this test report refer only to the sample(s) tested unless otherwise stated and the sample(s) are retained for 30 days only. The document is issued by AGC, this document cannot be reproduced except in full with our prior written permission. The more details and the authenticity of the report will be confirmed at <http://www.agc-cert.com>.



# Test Report

Report No.: AGC03778181201-006S2

Date: Jan.14, 2019

Page 7 of 10

Note: \* See figure:

Key: A =Reference points

X = Measure point

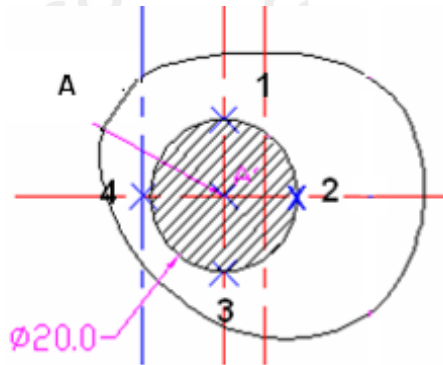

Figure: Measuring Location of refractive power

## Minimum robustness of filters — Clause 7.1

Sample Number	Defects		Comment	Result
	Observed	Absent		
1		X	--	P

Requirements:

None of the following defects shall appear on filters :

1. Filter fracture;
2. Filter deformation;

## Frame deformation and retention of filters —Clause 7.2

Sample Number	Boxed center Distance C (mm)	Residual Deformation X (mm)	Deformation Percentage Φ(%)	Structure		Lens Retention		Result
				Pass	Fail	Pass	Fail	
1	72.72	0.04	0.1	X		X		P

Requirements:

1. Be permanently deformed from its original configuration by not more than 2% of the distance C.,  
Deformation percentageΦ; Calculation:  $\Phi (\%) = X/C*100$
2. No fracture or crack at any point ;
3. No filter shall be displaced from the frame.

Measurement Uncertainty (if necessary):

The results shown in this test report refer only to the sample(s) tested unless otherwise stated and the sample(s) are retained for 30 days only. The document is issued by AGC, this document cannot be reproduced except in full with our prior written permission. The more details and the authenticity of the report will be confirmed at <http://www.agc-cert.com>.



# Test Report

**Report No.: AGC03778181201-006S2**

Date: Jan.14, 2019

Page 8 of 10

**Resistance to Radiation — Clause 8**

Sample No.: 1		Test Items	Requirements	Left	Right	Result(s)
The relative change of luminous transmittance		For Cat. 0: <math>\leq \pm 3\%</math>	Before exposure	17.9	18.5	P
		For Cat. 1: <math>\leq \pm 5\%</math>	After exposure	18.5	18.7	
		For Cat. 2: <math>\leq \pm 8\%</math>	Difference	3.4	1.1	
Wide angle scattering		After exposure, the value of wide angle scattering shall not exceed the limit value of 3%;		2.2	2.3	P
Requirements for the ultraviolet spectral range for $\tau_v$ (%)	$\tau_{SUVB}$ (280~315) nm (%)	For Cat. 0,1: $\leq 0.05\tau_v$ For Cat. 2: 1.0% absolute or $0.05\tau_v$ whichever is greater; For Cat. 3, 4: 1.0% absolute		0.0	0.0	P
	$\tau_{SUVA}$ (315~380) nm (%)	For Cat. 0,1: $\leq \tau_v$ ; For Cat. 2, 3: $\leq 0.5\tau_v$ For Cat. 4: 1.0% absolute or $0.25\tau_v$ whichever is greater;		0.0	0.0	P

Measurement Uncertainty (if necessary):

**Ignition—Clause 9**

Sample Number	Continued combustion		Comment	Result
	Yes	No		
1		X	--	P

**Requirements:**

The filters and frame shall be no continued combustion after withdrawal of the test rod.

The results shown in this test report refer only to the sample(s) tested unless otherwise stated and the sample(s) are retained for 30 days only. The document is issued by AGC, this document cannot be reproduced except in full with our prior written permission. The more details and the authenticity of the report will be confirmed at <http://www.agc-cert.com>.





# Test Report

**Report No.: AGC03778181201-006S2**

Date: Jan.14, 2019

Page 9 of 10

**Coverage area — Clause 11.1**

Sample Number	Type (Adult/Children)	Test Position	Coverage area		Comment	Result
			Pass	Fail		
1	Adults	Left	X		--	P
		Right	X		--	P

**Requirements:**

- Adults' sunglasses shall cover two ellipses of horizontal diameter of 40mm and a vertical diameter of 28mm, the centres of which are separated 64mm and symmetrically placed on either side of the centre of the nose bridge of the frame.
- Children's sunglasses shall cover two ellipses of horizontal diameter of 34mm and a vertical diameter of 24mm, the centres of which are separated 54mm and symmetrically placed on either side of the centre of the nose bridge of the frame.

**Sample description:**

1	Green lens
---	------------

The results shown in this test report refer only to the sample(s) tested unless otherwise stated and the sample(s) are retained for 30 days only. The document is issued by AGC, this document cannot be reproduced except in full with our prior written permission. The more details and the authenticity of the report will be confirmed at <http://www.agc-cert.com>.



# Test Report

Report No.: AGC03778181201-006S2

Date: Jan.14, 2019

Page 10 of 10

## Sample Information

Model	Sample Name
MO9034-48	plastic bi-color outer in Black and inner in Lime with lime mirror lens
MO9521-48	Stainless iron silver color with lime mirror lens(lime pouch)
MO8652-09	plastic Transparent frosty white frame and green leg with lime mirror lens
MO9022-40	plastic in wood pattern and matt finish with green mirror lens

This report is to supersede the report with No.: AGC03778181201-006S1 dated on Dec.21,2018.

## The photo of the sample



**AGC03778181201-006S2**

AGC authenticate the photo on original report only

\*\*\* End of Report\*\*\*

The results shown in this test report refer only to the sample(s) tested unless otherwise stated and the sample(s) are retained for 30 days only. The document is issued by AGC, this document cannot be reproduced except in full with our prior written permission. The more details and the authenticity of the report will be confirmed at <http://www.agc-cert.com>.





# Test Report

Report No.: AGC03778181201-004S1

Date: Dec.21, 2018

Page 1 of 10

Applicant: MID OCEAN BRANDS B.V

Address: 7/F, Kings Tower, 111 King Lam Street, Cheung Sha Wan, Kowloon, Hong Kong

## Report on the submitted samples said to be:

Sample Name : See Sample Information  
Model : See Sample Information  
Manufacturers : 101191  
Sample Receiving Date : Dec.03, 2018  
Testing Period : Dec.03, 2018 to Dec.18, 2018

Test Method : Please refer to next page(s).

Test Result : Please refer to next page(s).

## Test Requested

1.ISO 12312-1:2013+A1:2015, excluding:  
- Clause 12 Information and labeling

## Conclusion

Pass



Approved by: Jay. Liu

Liujiuliang, Jay.Liu

Laboratory Supervisor



The results shown in this test report refer only to the sample(s) tested unless otherwise stated and the sample(s) are retained for 30 days only. The document is issued by AGC, this document cannot be reproduced except in full with our prior written permission. The more details and the authenticity of the report will be confirmed at <http://www.agc-cert.com>.

# Test Report

**Report No.: AGC03778181201-004S1**

Date: Dec.21, 2018

Page 2 of 10

**1.Tests Conducted Summary:**
**(1) Requirements for Sunglasses**

Test standard: - ISO 12312-1:2013+A1:2015      Eye and face protection — Sunglasses and related eyewear  
 — Part 1: Sunglasses for general use  
 - ISO 12311:2013      Personal protective equipment —Test methods for  
 Sunglasses and related eyewear

Note: The applicant's attention was drawn that the manufacturer should not use the frame materials which are known to cause irritation, allergic or toxic reaction during wear in a normal state of health against significant proportion of users.

CLAUSES	REQUIREMENTS		RESULT
4	Construction and materials		
4.1	Construction		P
4.2	Filter material and surface quality		P
4.3	Physiological compatibility (Nickel Release)		NA
5	Transmittance		
5.2	Transmittance and filter categories	Filter categories	Cat.3
		UV requirements	P
5.3	General transmittance requirements		
5.3.1	Uniformity of luminous transmittance		P
5.3.2	Requirements for road use and driving	5.3.2.2 Spectral transmittance	P
		5.3.2.3 Detection of signal lights	P
		5.3.2.4 Driving in twilight or at night	NA
5.3.3	Wide angle scattering		P
5.3.4	Additional transmittance requirements for specific filter types	5.3.4.1 Photochromic filters	NA
		5.3.4.2 Polarizing filters	NA
		5.3.4.3 Gradient filters	NA
6	Refractive power		
6.1	Spherical and astigmatic power		P
6.2	Local variations in refractive power		P
6.3	Prism imbalance (relative prism error)		P

The results shown in this test report refer only to the sample(s) tested unless otherwise stated and the sample(s) are retained for 30 days only. The document is issued by AGC, this document cannot be reproduced except in full with our prior written permission. The more details and the authenticity of the report will be confirmed at <http://www.agc-cert.com>.





# Test Report

**Report No.: AGC03778181201-004S1**

Date: Dec.21, 2018

Page 3 of 10

CLAUSES	REQUIREMENTS	RESULT
7	Robustness	
7.1	Minimum robustness of filters	P
7.2	Frame deformation and retention of filters	P
8	Resistance to solar radiation	P
9	Resistance to ignition	P
11	Protective requirements	
11.1	Coverage area	P
12	Information and labeling	
12.1	Information to be supplied with each pair of sunglasses	NR
12.2	Additional information	NR

**Remark:** P=Pass; F=Fail; NA=Not Applicable; NR=Not Require; X=Checked; Cat.=Category;

## Test Results

### Construction—Clause 4.1 and Filter material and surface quality —Clause 4.2

Sample Number	Defects				Comment	Result
	Construction		Filter material and surface quality			
	Observed	Absent	Observed	Absent		
1		X		X	--	P

#### Requirements:

- Construction shall be smooth and without sharp projections;
- Filter material and surface quality: Except in a marginal area 5 mm wide, sunglass filters shall have no material or machining defects within an area of 30mm diameter around the reference point that may impair vision, e.g. bubbles, scratches, inclusions, dull spots, pitting, mould marks, notches, reinforced points, specks, beads, water specks, pocking, gas inclusions, splintering, cracks, polishing defects or undulations.

The results shown in this test report refer only to the sample(s) tested unless otherwise stated and the sample(s) are retained for 30 days only. The document is issued by AGC, this document cannot be reproduced except in full with our prior written permission. The more details and the authenticity of the report will be confirmed at <http://www.agc-cert.com>.



# Test Report

**Report No.: AGC03778181201-004S1**

Date: Dec.21, 2018

Page 4 of 10

**Transmittance and filter categories — Clause 5.2**

Sample No.: 1				
Test Items	Requirements	Left	Right	Result(s)
Luminous transmittance $\tau_v$ (380~780)nm (%)	For Cat. 0: 80.0~100	13.3	13.4	Cat.3
	For Cat. 1: 43.0~80.0			
	For Cat. 2: 18.0~43.0			
	For Cat. 3: 8.0~18.0			
	For Cat. 4: 3.0~8.0			
Filter categories	Claimed Cat.: (Not Provided)			
$\tau_{SUVB}$ (280~315)nm (%)	For Cat.0, 1: $\leq 0.05\tau_v$ For Cat.2: 1.0% absolute or $0.05\tau_v$ whichever is greater; For Cat.3, 4: 1.0% absolute	0.0	0.0	P
$\tau_{SUVA}$ (315~380)nm (%)	For Cat.0, 1: $\leq \tau_v$ ; For Cat.2, 3: $\leq 0.5\tau_v$ For Cat.4: 1.0% absolute or $0.25\tau_v$ whichever is greater	0.0	0.1	P
$\tau_{sb}$ (380~500)nm (%)	---	10.8	10.2	Only Ref.

Measurement Uncertainty (if necessary):

The results shown in this test report refer only to the sample(s) tested unless otherwise stated and the sample(s) are retained for 30 days only. The document is issued by AGC, this document cannot be reproduced except in full with our prior written permission. The more details and the authenticity of the report will be confirmed at <http://www.agc-cert.com>.

**Attestation of Global Compliance Std. & Tech.**
**No.18 C**  
 Tel: +86-755 8358 3833 Fax: +86-755 2531 6612 E-mail: agc01@agc-cert.com 400 089 2118  
 Add: Building 2, No.171, Meihua Road, Shangmeilin, Futian District, Shenzhen, Guangdong China



# Test Report

**Report No.: AGC03778181201-004S1**

Date: Dec.21, 2018

Page 5 of 10

**Uniformity of luminous transmittance — Clause 5.3.1**

Sample No.: 1				
Test Items	Requirements	Left	Right	Result(s)
Difference within filter (%) (relative to higher value)	The relative difference in the luminous transmittance value shall not be greater than 10%, except for Cat. 4 where it shall not be greater than 20%	0.7	8.5	P
Difference with mounted filters (relative to higher value)	The relative difference between the luminous transmittance value of the visual center for right and left eye shall not exceed 15%	0.7		P

Measurement Uncertainty (if necessary):

**Requirements for road use and driving — Clause 5.3.2**

Sample No.: 1				
Test Items	Requirements	Left	Right	Result(s)
Categories	Filters suitable for road use and driving shall be categories 0, 1, 2 or 3	Cat.3	Cat.3	P
Spectral transmittance (475~650)nm (%)	$\cong 0.2\tau_v$	11.4 ( $0.2\tau_v=2.7$ )	11.8 ( $0.2\tau_v=2.7$ )	P
Red Signal	$\cong 0.80$	1.025	1.015	P
Yellow Signal	$\cong 0.60$	1.025	0.979	
Green Signal	$\cong 0.60$	1.017	1.020	
Blue Signal	$\cong 0.60$	1.074	1.052	
Driving in twilight or at night(%)	$\tau_v \cong 75\%$	13.3	13.4	NA

Measurement Uncertainty (if necessary):

The results shown in this test report refer only to the sample(s) tested unless otherwise stated and the sample(s) are retained for 30 days only. The document is issued by AGC, this document cannot be reproduced except in full with our prior written permission. The more details and the authenticity of the report will be confirmed at <http://www.agc-cert.com>.



# Test Report

**Report No.: AGC03778181201-004S1**

Date: Dec.21, 2018

Page 6 of 10

**Wide angle scattering—Clause 5.3.3**

Sample Number	Wide angle scattering(%)		Result
	Left	Right	
1	2.3	2.4	P

**Requirements:**

The wide angle scattering of the filters in the condition as supplied by the manufacturer shall not exceed the value of 3 %.

Measurement Uncertainty (if necessary):

**Refractive power—Clause 6**

Sample No.: 1						
Test Items	Requirements	Left	Right	Result(s)		
Spherical Power (D)	$\pm 0.12D$	+0.02	+0.01	P		
	The difference between the spherical powers shall not exceed 0.18 D;	0.01		P		
Astigmatic Power (D)	$\cong 0.12D$	0.00	0.00	P		
Local variations in refractive power (D)	Spherical Power	$\pm 0.12D$	1*	+0.01	P	
			2*	+0.02		+0.01
			3*	+0.01		+0.01
			4*	+0.02		+0.02
	Astigmatic Power	$\cong 0.12D$	1*	0.02	0.00	P
			2*	0.01	0.01	
			3*	0.01	0.02	
			4*	0.01	0.01	
Prism imbalance (cm/m)	Horizontal	Base Out: <1.00	0.18		P	
		Base In: <0.25	--			
	Vertical	<0.25	0.16			

Measurement Uncertainty (if necessary):

 The results shown in this test report refer only to the sample(s) tested unless otherwise stated and the sample(s) are retained for 30 days only. The document is issued by AGC, this document cannot be reproduced except in full with our prior written permission. The more details and the authenticity of the report will be confirmed at <http://www.agc-cert.com>.



# Test Report

Report No.: AGC03778181201-004S1

Date: Dec.21, 2018

Page 7 of 10

Note: \* See figure:

Key: A =Reference points

X = Measure point

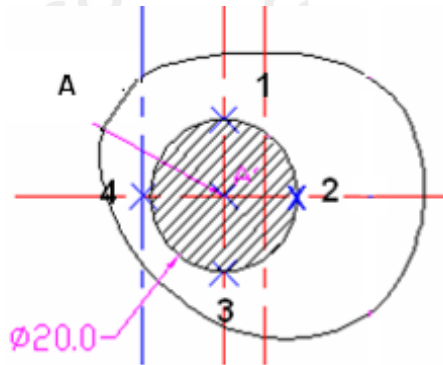

Figure: Measuring Location of refractive power

## Minimum robustness of filters — Clause 7.1

Sample Number	Defects		Comment	Result
	Observed	Absent		
1		X	--	P

Requirements:

None of the following defects shall appear on filters :

1. Filter fracture;
2. Filter deformation;

## Frame deformation and retention of filters — Clause 7.2

Sample Number	Boxed center Distance C (mm)	Residual Deformation X (mm)	Deformation Percentage $\Phi$ (%)	Structure		Lens Retention		Result
				Pass	Fail	Pass	Fail	
1	73.00	0.08	0.1	X		X		P

Requirements:

1. Be permanently deformed from its original configuration by not more than 2% of the distance C.,  
Deformation percentage  $\Phi$ ; Calculation:  $\Phi (\%) = X/C * 100$
2. No fracture or crack at any point ;
3. No filter shall be displaced from the frame.

Measurement Uncertainty (if necessary):

The results shown in this test report refer only to the sample(s) tested unless otherwise stated and the sample(s) are retained for 30 days only. The document is issued by AGC, this document cannot be reproduced except in full with our prior written permission. The more details and the authenticity of the report will be confirmed at <http://www.agc-cert.com>.



# Test Report

**Report No.: AGC03778181201-004S1**

Date: Dec.21, 2018

Page 8 of 10

**Resistance to Radiation — Clause 8**

Sample No.: 1		Test Items	Requirements	Left	Right	Result(s)
The relative change of luminous transmittance		For Cat. 0: $< \pm 3\%$	Before exposure	13.3	13.4	P
		For Cat. 1: $< \pm 5\%$	After exposure	13.4	13.3	
		For Cat. 2: $< \pm 8\%$	Difference	0.8	-0.7	
Wide angle scattering		After exposure, the value of wide angle scattering shall not exceed the limit value of 3%;		2.3	2.4	P
Requirements for the ultraviolet spectral range for $\tau_v$ (%)	$\tau_{SUVB}$ (280~315) nm (%)	For Cat. 0,1: $\leq 0.05\tau_v$ For Cat. 2: 1.0% absolute or $0.05\tau_v$ whichever is greater; For Cat. 3, 4: 1.0% absolute		0.0	0.0	P
	$\tau_{SUVA}$ (315~380) nm (%)	For Cat. 0,1: $\leq \tau_v$ ; For Cat. 2, 3: $\leq 0.5\tau_v$ For Cat. 4: 1.0% absolute or $0.25\tau_v$ whichever is greater;		0.0	0.0	P

Measurement Uncertainty (if necessary):

**Ignition—Clause 9**

Sample Number	Continued combustion		Comment	Result
	Yes	No		
1		X	--	P

**Requirements:**

The filters and frame shall be no continued combustion after withdrawal of the test rod.

The results shown in this test report refer only to the sample(s) tested unless otherwise stated and the sample(s) are retained for 30 days only. The document is issued by AGC, this document cannot be reproduced except in full with our prior written permission. The more details and the authenticity of the report will be confirmed at <http://www.agc-cert.com>.





# Test Report

**Report No.: AGC03778181201-004S1**

Date: Dec.21, 2018

Page 9 of 10

**Coverage area — Clause 11.1**

Sample Number	Type (Adult/Children)	Test Position	Coverage area		Comment	Result
			Pass	Fail		
1	Adults	Left	X		--	P
		Right	X		--	P

**Requirements:**

- Adults' sunglasses shall cover two ellipses of horizontal diameter of 40mm and a vertical diameter of 28mm, the centres of which are separated 64mm and symmetrically placed on either side of the centre of the nose bridge of the frame.
- Children's sunglasses shall cover two ellipses of horizontal diameter of 34mm and a vertical diameter of 24mm, the centres of which are separated 54mm and symmetrically placed on either side of the centre of the nose bridge of the frame.

**Sample description:**

1	Orange-yellow lens
---	--------------------

The results shown in this test report refer only to the sample(s) tested unless otherwise stated and the sample(s) are retained for 30 days only. The document is issued by AGC, this document cannot be reproduced except in full with our prior written permission. The more details and the authenticity of the report will be confirmed at <http://www.agc-cert.com>.



# Test Report

Report No.: AGC03778181201-004S1

Date: Dec.21, 2018

Page 10 of 10

## Sample Information

Model	Sample Name
MO9034-10	plastic bi-color outer in Black and inner in Orange with orange mirror lens
MO9521-10	Stainless iron gold color with orange mirror lens(orange pouch)
MO8652-10	plastic Transparent frosty white frame and orange leg with orange mirror lens

This report is to supersede the report with No.: AGC03778181201-004 dated on Dec.18,2018.

## The photo of the sample



**AGC03778181201-004S1**

AGC authenticate the photo on original report only

\*\*\* End of Report\*\*\*

The results shown in this test report refer only to the sample(s) tested unless otherwise stated and the sample(s) are retained for 30 days only. The document is issued by AGC, this document cannot be reproduced except in full with our prior written permission. The more details and the authenticity of the report will be confirmed at <http://www.agc-cert.com>.

**AGC**

Attestation of Global Compliance Std. & Tech.

Tel: +86-755 8358 3833 Fax: +86-755 2531 6612 E-mail: agc01@agc-cert.com 400 089 2118  
Add: Building 2, No. 171, Meihua Road, Shangmeilin, Futian District, Shenzhen, Guangdong China

**No.18 C**



# Test Report

Report No.: AGC03778181201-002S1

Date: Dec.21, 2018

Page 1 of 10

Applicant: MID OCEAN BRANDS B.V

Address: 7/F, Kings Tower, 111 King Lam Street, Cheung Sha Wan, Kowloon, Hong Kong

## Report on the submitted samples said to be:

Sample Name : See Sample Information  
Model : See Sample Information  
Manufacturers : 101191  
Sample Receiving Date : Dec.03, 2018  
Testing Period : Dec.03, 2018 to Dec.18, 2018

Test Method : Please refer to next page(s).

Test Result : Please refer to next page(s).

## Test Requested

1.ISO 12312-1:2013+A1:2015, excluding:  
- Clause 12 Information and labeling

## Conclusion

Pass



Approved by: Jay. Liu

Liujinliang, Jay.Liu

Laboratory Supervisor



The results shown in this test report refer only to the sample(s) tested unless otherwise stated and the sample(s) are retained for 30 days only. The document is issued by AGC, this document cannot be reproduced except in full with our prior written permission. The more details and the authenticity of the report will be confirmed at <http://www.agc-cert.com>.

# Test Report

**Report No.: AGC03778181201-002S1**

Date: Dec.21, 2018

Page 2 of 10

**1.Tests Conducted Summary:**
**(1) Requirements for Sunglasses**

Test standard: - ISO 12312-1:2013+A1:2015      Eye and face protection — Sunglasses and related eyewear  
 — Part 1: Sunglasses for general use  
 - ISO 12311:2013      Personal protective equipment —Test methods for  
 Sunglasses and related eyewear

Note: The applicant's attention was drawn that the manufacturer should not use the frame materials which are known to cause irritation, allergic or toxic reaction during wear in a normal state of health against significant proportion of users.

CLAUSES	REQUIREMENTS		RESULT
4	Construction and materials		
4.1	Construction		P
4.2	Filter material and surface quality		P
4.3	Physiological compatibility (Nickel Release)		NA
5	Transmittance		
5.2	Transmittance and filter categories	Filter categories	Cat.3
		UV requirements	P
5.3	General transmittance requirements		
5.3.1	Uniformity of luminous transmittance		P
5.3.2	Requirements for road use and driving	5.3.2.2 Spectral transmittance	P
		5.3.2.3 Detection of signal lights	P
		5.3.2.4 Driving in twilight or at night	NA
5.3.3	Wide angle scattering		P
5.3.4	Additional transmittance requirements for specific filter types	5.3.4.1 Photochromic filters	NA
		5.3.4.2 Polarizing filters	NA
		5.3.4.3 Gradient filters	NA
6	Refractive power		
6.1	Spherical and astigmatic power		P
6.2	Local variations in refractive power		P
6.3	Prism imbalance (relative prism error)		P

The results shown in this test report refer only to the sample(s) tested unless otherwise stated and the sample(s) are retained for 30 days only. The document is issued by AGC, this document cannot be reproduced except in full with our prior written permission. The more details and the authenticity of the report will be confirmed at <http://www.agc-cert.com>.





# Test Report

**Report No.: AGC03778181201-002S1**

Date: Dec.21, 2018

Page 3 of 10

CLAUSES	REQUIREMENTS	RESULT
7	Robustness	
7.1	Minimum robustness of filters	P
7.2	Frame deformation and retention of filters	P
8	Resistance to solar radiation	P
9	Resistance to ignition	P
11	Protective requirements	
11.1	Coverage area	P
12	Information and labeling	
12.1	Information to be supplied with each pair of sunglasses	NR
12.2	Additional information	NR

**Remark:** P=Pass; F=Fail; NA=Not Applicable; NR=Not Require; X=Checked; Cat.=Category;

## Test Results

### Construction—Clause 4.1 and Filter material and surface quality —Clause 4.2

Sample Number	Defects				Comment	Result
	Construction		Filter material and surface quality			
	Observed	Absent	Observed	Absent		
1		X		X	--	P

#### Requirements:

- Construction shall be smooth and without sharp projections;
- Filter material and surface quality: Except in a marginal area 5 mm wide, sunglass filters shall have no material or machining defects within an area of 30mm diameter around the reference point that may impair vision, e.g. bubbles, scratches, inclusions, dull spots, pitting, mould marks, notches, reinforced points, specks, beads, water specks, pocking, gas inclusions, splintering, cracks, polishing defects or undulations.

The results shown in this test report refer only to the sample(s) tested unless otherwise stated and the sample(s) are retained for 30 days only. The document is issued by AGC, this document cannot be reproduced except in full with our prior written permission. The more details and the authenticity of the report will be confirmed at <http://www.agc-cert.com>.



# Test Report

**Report No.: AGC03778181201-002S1**

Date: Dec.21, 2018

Page 4 of 10

**Transmittance and filter categories — Clause 5.2**

Sample No.: 1				
Test Items	Requirements	Left	Right	Result(s)
Luminous transmittance $\tau_v$ (380~780)nm (%)	For Cat. 0: 80.0~100	12.3	11.8	Cat.3
	For Cat. 1: 43.0~80.0			
	For Cat. 2: 18.0~43.0			
	For Cat. 3: 8.0~18.0			
	For Cat. 4: 3.0~8.0			
Filter categories	Claimed Cat.: (Not Provided)			
$\tau_{SUVB}$ (280~315)nm (%)	For Cat.0, 1: $\leq 0.05\tau_v$ For Cat.2: 1.0% absolute or $0.05\tau_v$ whichever is greater; For Cat.3, 4: 1.0% absolute	0.0	0.0	P
$\tau_{SUVA}$ (315~380)nm (%)	For Cat.0, 1: $\leq \tau_v$ ; For Cat.2, 3: $\leq 0.5\tau_v$ For Cat.4: 1.0% absolute or $0.25\tau_v$ whichever is greater	0.0	0.0	P
$\tau_{sb}$ (380~500)nm (%)	---	10.7	10.4	Only Ref.

Measurement Uncertainty (if necessary):

The results shown in this test report refer only to the sample(s) tested unless otherwise stated and the sample(s) are retained for 30 days only. The document is issued by AGC, this document cannot be reproduced except in full with our prior written permission. The more details and the authenticity of the report will be confirmed at <http://www.agc-cert.com>.



Attestation of Global Compliance Std. &amp; Tech.

**No.18 C**  
 Tel: +86-755 8358 3833 Fax: +86-755 2531 6612 E-mail: agc01@agc-cert.com 400 089 2118  
 Add: Building 2, No.171, Meihua Road, Shangmeilin, Futian District, Shenzhen, Guangdong China



# Test Report

**Report No.: AGC03778181201-002S1**

Date: Dec.21, 2018

Page 5 of 10

**Uniformity of luminous transmittance — Clause 5.3.1**

Sample No.: 1				
Test Items	Requirements	Left	Right	Result(s)
Difference within filter (%) (relative to higher value)	The relative difference in the luminous transmittance value shall not be greater than 10%, except for Cat. 4 where it shall not be greater than 20%	5.4	4.1	P
Difference with mounted filters (relative to higher value)	The relative difference between the luminous transmittance value of the visual center for right and left eye shall not exceed 15%	4.1		P

Measurement Uncertainty (if necessary):

**Requirements for road use and driving — Clause 5.3.2**

Sample No.: 1				
Test Items	Requirements	Left	Right	Result(s)
Categories	Filters suitable for road use and driving shall be categories 0, 1, 2 or 3	Cat.3	Cat.3	P
Spectral transmittance (475~650)nm (%)	$\cong 0.2\tau_v$	11.6 ( $0.2\tau_v=2.5$ )	11.0 ( $0.2\tau_v=2.4$ )	P
Red Signal	$\cong 0.80$	1.127	1.116	P
Yellow Signal	$\cong 0.60$	1.027	1.023	
Green Signal	$\cong 0.60$	0.984	0.987	
Blue Signal	$\cong 0.60$	1.003	1.008	
Driving in twilight or at night(%)	$\tau_v \cong 75\%$	12.3	11.8	NA

Measurement Uncertainty (if necessary):

The results shown in this test report refer only to the sample(s) tested unless otherwise stated and the sample(s) are retained for 30 days only. The document is issued by AGC, this document cannot be reproduced except in full with our prior written permission. The more details and the authenticity of the report will be confirmed at <http://www.agc-cert.com>.



# Test Report

**Report No.: AGC03778181201-002S1**

Date: Dec.21, 2018

Page 6 of 10

**Wide angle scattering—Clause 5.3.3**

Sample Number	Wide angle scattering(%)		Result
	Left	Right	
1	1.3	1.2	P

**Requirements:**

The wide angle scattering of the filters in the condition as supplied by the manufacturer shall not exceed the value of 3 %.

Measurement Uncertainty (if necessary):

**Refractive power—Clause 6**

Sample No.: 1					
Test Items	Requirements	Left	Right	Result(s)	
Spherical Power (D)	$\pm 0.12D$	+0.03	+0.02	P	
	The difference between the spherical powers shall not exceed 0.18 D;	0.01		P	
Astigmatic Power (D)	$\cong 0.12D$	0.00	0.00	P	
Local variations in refractive power (D)	Spherical Power	$\pm 0.12D$	1*	+0.01	P
		2*	+0.02	+0.01	
		3*	+0.01	+0.02	
		4*	+0.02	+0.01	
	Astigmatic Power	$\cong 0.12D$	1*	0.01	P
		2*	0.00	0.00	
		3*	0.01	0.01	
		4*	0.01	0.00	
Prism imbalance (cm/m)	Horizontal	Base Out: <1.00	0.00		
		Base In: <0.25	0.01		
	Vertical	<0.25	0.00		

Measurement Uncertainty (if necessary):

 The results shown in this test report refer only to the sample(s) tested unless otherwise stated and the sample(s) are retained for 30 days only. The document is issued by AGC, this document cannot be reproduced except in full with our prior written permission. The more details and the authenticity of the report will be confirmed at <http://www.agc-cert.com>.



# Test Report

Report No.: AGC03778181201-002S1

Date: Dec.21, 2018

Page 7 of 10

Note: \* See figure:

Key: A =Reference points

X = Measure point

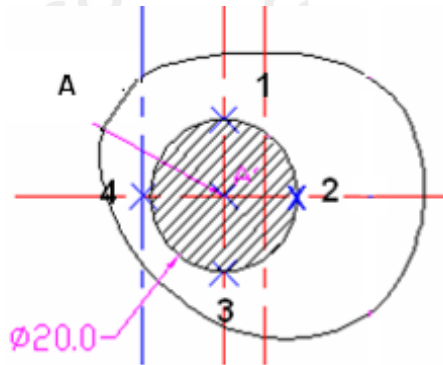

Figure: Measuring Location of refractive power

### Minimum robustness of filters — Clause 7.1

Sample Number	Defects		Comment	Result
	Observed	Absent		
1		X	--	P

Requirements:

None of the following defects shall appear on filters :

1. Filter fracture;
2. Filter deformation;

### Frame deformation and retention of filters — Clause 7.2

Sample Number	Boxed center Distance C (mm)	Residual Deformation X (mm)	Deformation Percentage $\Phi$ (%)	Structure		Lens Retention		Result
				Pass	Fail	Pass	Fail	
1	72.72	0.10	0.1	X		X		P

Requirements:

1. Be permanently deformed from its original configuration by not more than 2% of the distance C.,  
Deformation percentage  $\Phi$ ; Calculation:  $\Phi (\%) = X/C * 100$
2. No fracture or crack at any point ;
3. No filter shall be displaced from the frame.

Measurement Uncertainty (if necessary):

The results shown in this test report refer only to the sample(s) tested unless otherwise stated and the sample(s) are retained for 30 days only. The document is issued by AGC, this document cannot be reproduced except in full with our prior written permission. The more details and the authenticity of the report will be confirmed at <http://www.agc-cert.com>.



# Test Report

**Report No.: AGC03778181201-002S1**

Date: Dec.21, 2018

Page 8 of 10

**Resistance to Radiation — Clause 8**

Sample No.: 1						
Test Items		Requirements		Left	Right	Result(s)
The relative change of luminous transmittance		For Cat. 0: <math>\leq \pm 3\%</math>	Before exposure	12.3	11.8	P
		For Cat. 1: <math>\leq \pm 5\%</math>	After exposure	12.2	11.7	
		For Cat. 2: <math>\leq \pm 8\%</math>	Difference	-0.8	-0.8	
Wide angle scattering		After exposure, the value of wide angle scattering shall not exceed the limit value of 3%;		1.4	1.3	P
Requirements for the ultraviolet spectral range for $\tau_v$ (%)	$\tau_{SUVB}$ (280~315) nm (%)	For Cat. 0,1: $\leq 0.05\tau_v$ For Cat. 2: 1.0% absolute or $0.05\tau_v$ whichever is greater; For Cat. 3, 4: 1.0% absolute		0.0	0.0	P
	$\tau_{SUVA}$ (315~380) nm (%)	For Cat. 0,1: $\leq \tau_v$ ; For Cat. 2, 3: $\leq 0.5\tau_v$ For Cat. 4: 1.0% absolute or $0.25\tau_v$ whichever is greater;		0.0	0.0	P

Measurement Uncertainty (if necessary):

**Ignition—Clause 9**

Sample Number	Continued combustion		Comment	Result
	Yes	No		
1		X	--	P

**Requirements:**

The filters and frame shall be no continued combustion after withdrawal of the test rod.

The results shown in this test report refer only to the sample(s) tested unless otherwise stated and the sample(s) are retained for 30 days only. The document is issued by AGC, this document cannot be reproduced except in full with our prior written permission. The more details and the authenticity of the report will be confirmed at <http://www.agc-cert.com>.





# Test Report

Report No.: AGC03778181201-002S1

Date: Dec.21, 2018

Page 9 of 10

**Coverage area — Clause 11.1**

Sample Number	Type (Adult/Children)	Test Position	Coverage area		Comment	Result
			Pass	Fail		
1	Adults	Left	X		--	P
		Right	X		--	P

**Requirements:**

- Adults' sunglasses shall cover two ellipses of horizontal diameter of 40mm and a vertical diameter of 28mm, the centres of which are separated 64mm and symmetrically placed on either side of the centre of the nose bridge of the frame.
- Children's sunglasses shall cover two ellipses of horizontal diameter of 34mm and a vertical diameter of 24mm, the centres of which are separated 54mm and symmetrically placed on either side of the centre of the nose bridge of the frame.

**Sample description:**

1	Silver lens
---	-------------

The results shown in this test report refer only to the sample(s) tested unless otherwise stated and the sample(s) are retained for 30 days only. The document is issued by AGC, this document cannot be reproduced except in full with our prior written permission. The more details and the authenticity of the report will be confirmed at <http://www.agc-cert.com>.



# Test Report

Report No.: AGC03778181201-002S1

Date: Dec.21, 2018

Page 10 of 10

## Sample Information

Model	Sample Name
MO9034-06	plastic bi-color outer in Black and inner in White with silver mirror lens
MO9521-03	Stainless iron black color with silver mirror lens (black pouch)
MO9522-37	plastic royal blue color with silver mirror lens
MO9522-06	plastic white color with silver mirror lens
MO9522-03	plastic black color with silver mirror lens
MO8652-03	plastic Transparent frosty white frame and black leg with silver mirror lens

This report is to supersede the report with No.: AGC03778181201-002 dated on Dec.18,2018.

## The photo of the sample



**AGC03778181201-002S1**

AGC authenticate the photo on original report only

\*\*\* End of Report\*\*\*

The results shown in this test report refer only to the sample(s) tested unless otherwise stated and the sample(s) are retained for 30 days only. The document is issued by AGC, this document cannot be reproduced except in full with our prior written permission. The more details and the authenticity of the report will be confirmed at <http://www.agc-cert.com>.



# Test Report

**Report No.:** AGC03778190101-004

**Date:** Jan.18, 2019

**Page 1 of 3**

**Applicant:** MID OCEAN BRANDS B.V

**Address:** 7/F, Kings Tower, 111 King Lam Street, Cheung Sha Wan, Kowloon, Hong Kong

**Report on the submitted samples said to be:**

**Sample Name :** See Sample Information

**Model :** See Sample Information

**Manufacturers :** 101191

**Sample Receiving Date :** Jan.14, 2019

**Testing Period :** Jan.14, 2019 to Jan.18, 2019

**Test Method :** Please refer to next page(s).

**Test Result :** Please refer to next page(s).

**Test Requested:**

UV400 (In-house test, and test method refer to attached pages for details)

**Conclusion:**

Pass



Liujinliang, Jay.Liu

Laboratory Supervisor



The results shown in this test report refer only to the sample(s) tested unless otherwise stated and the sample(s) are retained for 30 days only. The document is issued by AGC, this document cannot be reproduced except in full with our prior written permission. The more details and the authenticity of the report will be confirmed at <http://www.agc-cert.com>.

# Test Report

**Report No.: AGC03778190101-004**

Date: Jan.18, 2019

Page 2 of 3

**Tests Conducted Summary**
**UV400**(In-house test, non-accredited test item)

As requested by the applicant, refer to test procedure of "Resistance to Radiation" in this report, assessment was made against a level of 100% UV protection, in which the spectral transmittance was examined within a range of 280nm-400nm before and after exposure.

Sample Number	Wavelength (nm)	Maximum Spectral transmittance (%)		Result
		Left	Right	
1	280-400	0.0	0.1	Pass

Requirements:

Maximum spectral transmittance shall not exceed 0.5%.

Measurement Uncertainty (if necessary):

**Sample description:**

1	Blue lens
---	-----------

**Sample Information**

Model	Sample Name
MO9034-37	plastic bi-color outer in Black and inner in Blue with blue mirror lens
MO9521-37	Stainless iron silver color with blue mirror lens (blue pouch)
MO8652-04	plastic Transparent frosty white frame and blue leg with blue mirror lens

The results shown in this test report refer only to the sample(s) tested unless otherwise stated and the sample(s) are retained for 30 days only. The document is issued by AGC, this document cannot be reproduced except in full with our prior written permission. The more details and the authenticity of the report will be confirmed at <http://www.agc-cert.com>.





# Test Report

Report No.: AGC03778190101-004

Date: Jan.18, 2019

Page 3 of 3

## The photo of the sample



AGC03778190101-004

AGC authenticate the photo on original report only

\*\*\* End of Report\*\*\*

The results shown in this test report refer only to the sample(s) tested unless otherwise stated and the sample(s) are retained for 30 days only. The document is issued by AGC, this document cannot be reproduced except in full with our prior written permission. The more details and the authenticity of the report will be confirmed at <http://www.agc-cert.com>.

**AGC**

Attestation of Global Compliance Std. & Tech.

Tel: +86-755 8358 3833 Fax: +86-755 2531 6612 E-mail: agc01@agc-cert.com 400 089 2118  
Add: Building 2, No. 171, Meihua Road, Shangmeilin, Futian District, Shenzhen, Guangdong China

**No.18 C**

# Test Report

**Report No.:** AGC03778190101-005

**Date:** Jan.18, 2019

**Page 1 of 3**

**Applicant:** MID OCEAN BRANDS B.V

**Address:** 7/F, Kings Tower, 111 King Lam Street, Cheung Sha Wan, Kowloon, Hong Kong

**Report on the submitted samples said to be:**

**Sample Name :** See Sample Information

**Model :** See Sample Information

**Manufacturers :** 101191

**Sample Receiving Date :** Jan.14, 2019

**Testing Period :** Jan.14, 2019 to Jan.18, 2019

**Test Method :** Please refer to next page(s).

**Test Result :** Please refer to next page(s).

**Test Requested:**

UV400 (In-house test, and test method refer to attached pages for details)

**Conclusion:**

Pass



Liujinliang, Jay.Liu

Laboratory Supervisor



The results shown in this test report refer only to the sample(s) tested unless otherwise stated and the sample(s) are retained for 30 days only. The document is issued by AGC, this document cannot be reproduced except in full with our prior written permission. The more details and the authenticity of the report will be confirmed at <http://www.agc-cert.com>.



# Test Report

**Report No.: AGC03778190101-005**

Date: Jan.18, 2019

Page 2 of 3

**Tests Conducted Summary**
**UV400**(In-house test, non-accredited test item)

As requested by the applicant, refer to test procedure of "Resistance to Radiation" in this report, assessment was made against a level of 100% UV protection, in which the spectral transmittance was examined within a range of 280nm-400nm before and after exposure.

Sample Number	Wavelength (nm)	Maximum Spectral transmittance (%)		Result
		Left	Right	
1	280-400	0.1	0.1	Pass

Requirements:

Maximum spectral transmittance shall not exceed 0.5%.

Measurement Uncertainty (if necessary):

**Sample description:**

1	Green lens
---	------------

**Sample Information**

Model	Sample Name
MO9034-48	plastic bi-color outer in Black and inner in Lime with lime mirror lens
MO9521-48	Stainless iron silver color with lime mirror lens(lime pouch)
MO8652-09	plastic Transparent frosty white frame and green leg with lime mirror lens
MO9022-40	plastic in wood pattern and matt finish with green mirror lens

The results shown in this test report refer only to the sample(s) tested unless otherwise stated and the sample(s) are retained for 30 days only. The document is issued by AGC, this document cannot be reproduced except in full with our prior written permission. The more details and the authenticity of the report will be confirmed at <http://www.agc-cert.com>.



# Test Report

Report No.: AGC03778190101-005

Date: Jan.18, 2019

Page 3 of 3

## The photo of the sample



AGC03778190101-005

AGC authenticate the photo on original report only

\*\*\* End of Report\*\*\*

The results shown in this test report refer only to the sample(s) tested unless otherwise stated and the sample(s) are retained for 30 days only. The document is issued by AGC, this document cannot be reproduced except in full with our prior written permission. The more details and the authenticity of the report will be confirmed at <http://www.agc-cert.com>.

**AGC**

Attestation of Global Compliance Std. & Tech.

**No.18 C**

Tel: +86-755 8358 3833 Fax: +86-755 2531 6612 E-mail: agc01@agc-cert.com 400 089 2118  
Add: Building 2, No. 171, Meihua Road, Shangmeilin, Futian District, Shenzhen, Guangdong China



# Test Report

**Report No.:** AGC03778190101-003

**Date:** Jan.18, 2019

**Page 1 of 3**

**Applicant:** MID OCEAN BRANDS B.V

**Address:** 7/F, Kings Tower, 111 King Lam Street, Cheung Sha Wan, Kowloon, Hong Kong

**Report on the submitted samples said to be:**

**Sample Name :** See Sample Information

**Model :** See Sample Information

**Manufacturers :** 101191

**Sample Receiving Date :** Jan.14, 2019

**Testing Period :** Jan.14, 2019 to Jan.18, 2019

**Test Method :** Please refer to next page(s).

**Test Result :** Please refer to next page(s).

**Test Requested:**

UV400 (In-house test, and test method refer to attached pages for details)

**Conclusion:**

Pass



The results shown in this test report refer only to the sample(s) tested unless otherwise stated and the sample(s) are retained for 30 days only. The document is issued by AGC, this document cannot be reproduced except in full with our prior written permission. The more details and the authenticity of the report will be confirmed at <http://www.agc-cert.com>.

# Test Report

**Report No.: AGC03778190101-003**

Date: Jan.18, 2019

Page 2 of 3

**Tests Conducted Summary**
**UV400**(In-house test, non-accredited test item)

As requested by the applicant, refer to test procedure of "Resistance to Radiation" in this report, assessment was made against a level of 100% UV protection, in which the spectral transmittance was examined within a range of 280nm-400nm before and after exposure.

Sample Number	Wavelength (nm)	Maximum Spectral transmittance (%)		Result
		Left	Right	
1	280-400	0.1	0.0	Pass

Requirements:

Maximum spectral transmittance shall not exceed 0.5%.

Measurement Uncertainty (if necessary):

**Sample description:**

1	Orange-yellow lens
---	--------------------

**Sample Information**

Model	Sample Name
MO9034-10	plastic bi-color outer in Black and inner in Orange with orange mirror lens
MO9521-10	Stainless iron gold color with orange mirror lens(orange pouch)
MO8652-10	plastic Transparent frosty white frame and orange leg with orange mirror lens

The results shown in this test report refer only to the sample(s) tested unless otherwise stated and the sample(s) are retained for 30 days only. The document is issued by AGC, this document cannot be reproduced except in full with our prior written permission. The more details and the authenticity of the report will be confirmed at <http://www.agc-cert.com>.





# Test Report

Report No.: AGC03778190101-003

Date: Jan.18, 2019

Page 3 of 3

## The photo of the sample



**AGC03778190101-003**

AGC authenticate the photo on original report only

\*\*\* End of Report\*\*\*

The results shown in this test report refer only to the sample(s) tested unless otherwise stated and the sample(s) are retained for 30 days only. The document is issued by AGC, this document cannot be reproduced except in full with our prior written permission. The more details and the authenticity of the report will be confirmed at <http://www.agc-cert.com>.

**AGC**

Attestation of Global Compliance Std. & Tech.

**No.18 C**

Tel: +86-755 8358 3833 Fax: +86-755 2531 6612 E-mail: agc01@agc-cert.com 400 089 2118  
Add: Building 2, No.171, Meihua Road, Shangmeilin, Futian District, Shenzhen, Guangdong China

# Test Report

Report No.: AGC03778190101-001

Date: Jan.18, 2019

Page 1 of 3

Applicant: MID OCEAN BRANDS B.V

Address: 7/F, Kings Tower, 111 King Lam Street, Cheung Sha Wan, Kowloon, Hong Kong

## Report on the submitted samples said to be:

Sample Name : See Sample Information

Model : See Sample Information

Manufacturers : 101191

Sample Receiving Date : Jan.14, 2019

Testing Period : Jan.14, 2019 to Jan.18, 2019

Test Method : Please refer to next page(s).

Test Result : Please refer to next page(s).

## Test Requested:

UV400 (In-house test, and test method refer to attached pages for details)

## Conclusion:

Pass



Liujinliang, Jay.Liu

Laboratory Supervisor



The results shown in this test report refer only to the sample(s) tested unless otherwise stated and the sample(s) are retained for 30 days only. The document is issued by AGC, this document cannot be reproduced except in full with our prior written permission. The more details and the authenticity of the report will be confirmed at <http://www.agc-cert.com>.



# Test Report

**Report No.: AGC03778190101-001**

Date: Jan.18, 2019

Page 2 of 3

**Tests Conducted Summary**
**UV400**(In-house test, non-accredited test item)

As requested by the applicant, refer to test procedure of "Resistance to Radiation" in this report, assessment was made against a level of 100% UV protection, in which the spectral transmittance was examined within a range of 280nm-400nm before and after exposure.

Sample Number	Wavelength (nm)	Maximum Spectral transmittance (%)		Result
		Left	Right	
1	280-400	0.0	0.1	Pass

Requirements:

Maximum spectral transmittance shall not exceed 0.5%.

Measurement Uncertainty (if necessary):

**Sample description:**

1	Silver lens
---	-------------

**Sample Information**

Model	Sample Name
MO9034-06	plastic bi-color outer in Black and inner in White with silver mirror lens
MO9521-03	Stainless iron black color with silver mirror lens (black pouch)
MO9522-37	plastic royal blue color with silver mirror lens
MO9522-06	plastic white color with silver mirror lens
MO9522-03	plastic black color with silver mirror lens
MO8652-03	plastic Transparent frosty white frame and black leg with silver mirror lens

The results shown in this test report refer only to the sample(s) tested unless otherwise stated and the sample(s) are retained for 30 days only. The document is issued by AGC, this document cannot be reproduced except in full with our prior written permission. The more details and the authenticity of the report will be confirmed at <http://www.agc-cert.com>.



# Test Report

Report No.: AGC03778190101-001

Date: Jan.18, 2019

Page 3 of 3

## The photo of the sample



AGC03778190101-001

AGC authenticate the photo on original report only

\*\*\* End of Report\*\*\*

The results shown in this test report refer only to the sample(s) tested unless otherwise stated and the sample(s) are retained for 30 days only. The document is issued by AGC, this document cannot be reproduced except in full with our prior written permission. The more details and the authenticity of the report will be confirmed at <http://www.agc-cert.com>.

**AGC**

Attestation of Global Compliance Std. & Tech.

**No.18 C**

Tel: +86-755 8358 3833 Fax: +86-755 2531 6612 E-mail: agc01@agc-cert.com 400 089 2118  
Add: Building 2, No.171, Meihua Road, Shangmeilin, Futian District, Shenzhen, Guangdong China